

DESCRIPTION	REVISION							
	DATE	COR.	CHK.	APP.	APP.	APP.	APP.	APP.

REG	STATE	PROJECT	SHEET NO.	TOTAL SHEETS
3	D.C.		45	80

GENERAL NOTES

- ALL CONSTRUCTION MATERIALS AND PROCEDURES SHALL BE GOVERNED BY THE STANDARD SPECIFICATIONS FOR HIGHWAYS AND STRUCTURES DATED 2013, ISSUED BY THE DISTRICT OF COLUMBIA DEPARTMENT OF TRANSPORTATION, EXCEPT AS AMENDED BY THE SPECIAL PROVISIONS.
- THE CONTRACTOR IS RESPONSIBLE FOR CONTACTING MISS UTILITY PRIOR TO BEGINNING WORK. ANY DAMAGE TO UTILITIES MUST BE REPAIRED OR REPLACED BY THE CONTRACTOR AT HIS OR HER OWN EXPENSE.
- THE CONTRACTOR SHALL TAKE ADEQUATE PRECAUTION TO PROTECT ALL WALKS, GRADING, SIDEWALKS, AND FEATURES OUTSIDE THE LIMITS OF WORK, AND SHALL REPAIR AND REPLACE, OR OTHERWISE MAKE GOOD, AS DIRECTED BY THE ENGINEER ANY SUCH OR OTHER DAMAGE SO CAUSED.
- ALL STRIPING AND SIGN WORK SHALL MEET ALL APPLICABLE DDOT STANDARDS AND SPECIFICATIONS AND 2009 MANUAL ON UNIFORM TRAFFIC CONTROL DEVICES (MUTCD) REQUIREMENTS.
- ALL PAVEMENT MARKINGS ARE THERMOPLASTIC UNLESS OTHERWISE NOTED.
- ALL EXISTING PAVEMENT MARKINGS MAY NOT BE SHOWN. ALL EXISTING PAVEMENT MARKINGS THAT CONFLICT WITH PROPOSED PAVEMENT MARKINGS SHALL BE ERADICATED BY A METHOD APPROVED BY DDOT.
- NOT ALL FIRE HYDRANTS HAVE BEEN LOCATED FOR THIS STRIPING PLAN. FIELD VERIFY FIRE HYDRANT LOCATIONS, AND STRIPE NO PARKING ZONE FOR 10 FEET ON EITHER SIDE OF FIRE HYDRANT. IF HYDRANT IS LOCATED WITHIN 25 FEET OF A CROSSWALK ON APPROACH SIDE, EXTEND NO PARKING ZONE STRIPING TO 10 FEET BEYOND FIRE HYDRANT. FOR DEPARTURE SIDE OF ROAD, IF HYDRANT IS LOCATED WITHIN 25 FEET OF CROSSWALK, EXTEND NO PARKING ZONE STRIPING TO 10 FEET BEYOND FIRE HYDRANT.
- FIELD VERIFY DRIVEWAY LOCATIONS BEFORE APPLYING STRIPING.
- ALL SIGNS SHALL BE HIGH INTENSITY SHEETING MEETING THE REQUIREMENTS OF AASHTO M268.
- PROPOSED SIGNS SHALL BE INSTALLED SO THAT NO PORTION OF THE SIGN PANEL OVERHANGS ADJACENT ROADWAY PAVEMENT, I.E. SHALL NOT HANG IN FRONT OF A FACE OF CURB.
- PROPOSED SIGN POSTS SHALL BE LOCATED A MINIMUM OF 2 FEET BEHIND ANY ADJACENT FACE OF CURB. IF LOCATED IN OR ADJACENT TO SIDEWALKS, A 32" MINIMUM CLEAR AND 48" PREFERRED PASSING SPACE ON EXISTING AND PROPOSED SIDEWALKS SHALL BE MAINTAINED.
- PROPOSED SIGNS AT NEW LOCATIONS SHALL BE INSTALLED SO THEY DO NOT BLOCK THE VISIBILITY OF ANY EXISTING SIGNS OR SIGNALS.
- PROPOSED SIGNS AND POSTS SHALL BE CLEAR OF EXISTING FIRE HYDRANTS, SURFACE UTILITY, AND OVERHEAD UTILITY EQUIPMENT BY A MINIMUM OF 10 FEET.
- FOR NEW POST INSTALLATION, THE CONTRACTOR SHALL VERIFY THAT THERE ARE NO CONFLICTING UNDERGROUND OR OVERHEAD UTILITIES.
- SIGNS MOUNTED TO EXISTING LIGHT, SIGNAL, OR UTILITY POLES SHALL BE FASTENED WITH A MANUFACTURED STEEL BANDING SYSTEM. POLES SHALL NOT BE DRILLED DIRECTLY. THE CONTRACTOR SHALL SUBMIT MANUFACTURER INFORMATION ON THE BANDING SYSTEM TO THE ENGINEER FOR APPROVAL PRIOR TO INSTALLATION.
- IF SIGN INSTALLATION IS SHOWN ON A POLE THAT IS NOT OWNED BY THE CITY, WRITTEN PERMISSION MUST BE OBTAINED FROM THE OWNER (UTILITY COMPANY OR PROPERTY OWNER). THE CONTRACTOR IS RESPONSIBLE FOR OBTAINING REQUIRED PERMISSION.
- ALL PARKING RESTRICTION SIGNS SHALL BE INSTALLED AT A 45 DEGREE ANGLE FACING THE LINE OF TRAFFIC FLOW.
- THE CONTRACTOR SHALL USE EXISTING SIGNS AS TEMPLATES FOR PROPOSED NON-STANDARD IN-KIND REPLACEMENT, UNLESS OTHERWISE DETAILED ON THE PLANS.
- THE CONTRACTOR SHALL LAYOUT THE PROPOSED PAVEMENT MARKING CROSS-SECTIONS IN THE FIELD AND CONFIRM DIMENSIONS BEFORE APPLYING THE FINAL MARKINGS. THE CONTRACTOR SHALL NOTIFY THE ENGINEER IMMEDIATELY OF ANY DISCREPANCIES OR CHANGES TO PROPOSED LANE WIDTHS.

3/22/2022 R:\2019\08 DD01 ID0 Traffic Eng Des JMT\Task 17 - Park Place PBL\Dwg\Signing\pSN-000_Park Pl.dgn



100 M STREET SE
SUITE 550
WASHINGTON, DC 20003
(202) 570-7080
WWW.MEADHUNT.COM

S.L.F. NO. _____
APPROVED BY _____ DATE _____

PS&E DESIGN
MARCH 2022
Not for Construction

DISTRICT OF COLUMBIA DEPARTMENT OF TRANSPORTATION TRAFFIC ENGINEERING AND SAFETY DIVISION		FINAL FIELD CHECKED BY MP/TK
PARK PLACE /5TH STREET PROTECTED BIKE LANE FROM GRANT CIRCLE NW TO KENYON STREET NW, PARK ROAD WESTBOUND ONE-WAYING FROM GEORGIA AVENUE NW TO PARK PLACE NW SIGNING AND PAVEMENT MARKING GENERAL NOTES		DESIGNED BY MP
RECOMMENDED FOR APPROVAL:		REVIEWED BY RF
TRAFFIC SIGNAL DESIGN ENGINEER _____	DATE	03 /2022
TRAFFIC SIGNAL PROGRAM MANAGER _____	SCALE	NTS
APPROVED:	SHEET	OF
TRAFFIC SIGNAL DIVISION MANAGER /ASSOCIATE DIRECTOR _____	45	80
DATE: _____	DRAWING NO.	SN-0

REG	STATE	PROJECT	SHEET NO.	TOTAL SHEETS
3	D.C.		46	80

DESCRIPTION	REVISION							
	DATE	COR.	CHK.	APP.	APP.	APP.	APP.	APP.

DETAIL OF PAVEMENT MARKINGS

ROADWAY

- APPROACH LANE LINES TO A SIGNALIZED INTERSECTION - SINGLE SOLID WHITE LINE, SIX INCHES WIDE. BEGIN AT STOP LINE AND CONTINUE FOR NINETY FEET.
- BROKEN (DASHED) LINES
 - SINGLE SOLID WHITE LINE, FOUR INCHES WIDE, TEN FEET LONG; SKIP SPACES THIRTY FEET LONG. THE LAST DASH LINE OF EACH BLOCK WILL VARY IN LENGTH. IF IT IS SHORTER THAN TEN FEET, CONNECT TO NEXT TO LAST DASH LINE.
 - DASH LINES STOP ONE FOOT BEFORE CROSSWALK BACK EDGE LINE.
- DOTTED LINES - SINGLE SOLID WHITE LINE, FOUR INCHES WIDE, TWO FEET LONG; SKIP SPACES FOUR FEET LONG.
- DOUBLE YELLOW LINE - FOUR INCHES WIDE, LOCATED FOUR INCHES APART.
- ARROW OR TEXT MARKINGS - SPACED THIRTY-TWO FEET APART. SPACED FIFTEEN FEET FROM CROSSWALK.

STOP LINES

- 12 INCH WIDE WHITE STRIPE, LOCATED FOUR FEET BEFORE CROSSWALK (UNLESS OTHERWISE SHOWN).

CROSSWALKS

- PEDESTRIAN CROSSWALK - WIDTH AS SHOWN ON PLANS.
 - EDGE LINES - SOLID WHITE LINES, SIX INCHES WIDE.
 - STRIPED CROSSWALK - TWENTY-FOUR INCH WIDE WHITE STRIPES WITH TWENTY-FOUR INCH WIDE SPACING. MAKE STRIPES PARALLEL TO CURB LINE OF STREET.
 - ALL CURB RAMPS MUST BE LOCATED WITHIN A CROSSWALK, INCLUDING SIDE FLARES OF RAMPS. ONE SIDE FLARE MUST ALIGN WITH BACK EDGE OF CROSSWALK IF CROSSWALK WIDTH IS GREATER THAN FIFTEEN FEET. MAXIMUM WIDTH OF CROSSWALKS IS TWENTY FEET.

BIKE LANES

- GREEN COLORED BICYCLE CROSSING - WIDTH AS SHOWN ON PLANS.
 - EDGE LINES - SOLID WHITE LINES, SIX INCHES WIDE, PLACED ON SHORT EDGES FOR ONE-WAY TRAVEL. SOLID YELLOW LINES, SIX INCHES WIDE, PLACED ON SHORT EDGES FOR ONE-WAY CONTRAFLOW TRAVEL.
 - STRIPED EXTENSION LINE - TWO FOOT WIDE GREEN STRIPES WITH FOUR FOOT WIDE SPACING. MAKE STRIPES PARALLEL TO CURB LINE OF STREET.
- GREEN COLORED BICYCLE QUEUE BOX - GREEN WITH SIX INCH WIDE WHITE STRIPES AROUND EDGE.
- YIELD LINES - SOLID WHITE TRIANGLES, NINE INCHES WIDE, 13.5 INCHES TALL, EIGHTEEN INCH ON CENTER SPACING.
- SYMBOL PLACEMENT
 - DO NOT PLACE SYMBOLS ON LANE LINES.
 - PLACE LANE SYMBOLS WITHIN CENTER OF EACH BIKE LANE.
 - SEE PLAN SHEETS FOR SYMBOL LOCATIONS.
- 28" or 36" WHITE OR YELLOW FLEXIBLE CHANNELIZER POST
 - INSTALLATION TO BE COMPLETED IN ACCORDANCE WITH MANUFACTURER'S SPECIFICATIONS.
 - DIMENSIONS, MATERIALS, AND ATTACHMENTS MAY VARY BETWEEN MANUFACTURERS.
 - COLOR OF POST SHALL MATCH COLOR OF APPLICABLE EDGE LINE.

LATERAL STRIPING DIMENSIONS

- LATERAL PAVEMENT MARKING DIMENSIONS ARE TYPICALLY MEASURED TO AN ADJACENT FACE OF CURB OR TO THE CENTERLINE OF AN ADJACENT PAVEMENT MARKING (AS SHOWN IN THE DRAWINGS).

SIGNING & PAVEMENT MARKING LEGEND

EXISTING	PROPOSED	
		SIGN ON SIGNAL POLE
		SIGN ON LIGHT POLE
		SIGN AND SINGLE-POST
		SIGN AND DOUBLE-POST
		PAVEMENT MARKING LEGEND & ARROW
		WHITE OR YELLOW FLEXIBLE CHANNELIZER POST
		SIGN PANEL
		SIGN PANEL TO BE REMOVED

PS&E DESIGN
MARCH 2022
Not for Construction

DISTRICT OF COLUMBIA DEPARTMENT OF TRANSPORTATION TRAFFIC ENGINEERING AND SAFETY DIVISION		FINAL
"PARK PLACE 75TH STREET PROTECTED BIKE LANE" FROM GRANT CIRCLE NW TO KENYON STREET NW, PARK ROAD WESTBOUND ONE-WAYING FROM GEORGIA AVENUE NW TO PARK PLACE NW SIGNING AND PAVEMENT MARKING DETAIL-1		FIELD CHECKED BY MPTK
DESIGNED BY MP		DESIGNED BY MP
DRAWN BY MP		DRAWN BY MP
RECOMMENDED FOR APPROVAL:		REVIEWED BY RF
TRAFFIC SIGNAL DESIGN ENGINEER		DATE 03 /2022
TRAFFIC SIGNAL PROGRAM MANAGER		SCALE 1" = 20'
APPROVED:		SHEET 46
TRAFFIC SIGNAL DIVISION MANAGER /ASSOCIATE DIRECTOR		OF 80
DATE:		DRAWING NO. SN-DE1

Mead & Hunt
100 M STREET SE
SUITE 550
WASHINGTON, DC 20003
(202) 570-7080
WWW.MEADHUNT.COM

S.I.F. NO. _____
APPROVED BY _____ DATE _____

3/22/2022 RA\2019\08 DD01 ID10 Traffic Eng_Des_JMT\Task 17 - Park Place_PBL\Draw_Signing\pSN-DD01_Park_Pldgn

REG	STATE	PROJECT	SHEET NO.	TOTAL SHEETS
3	D.C.		47	80

DESCRIPTION	REVISION							
	DATE	COR.	CHK.	APP.	APP.	APP.	APP.	APP.

NOTE:
1. LATERAL PAVEMENT MARKING DIMENSIONS ARE TYPICALLY MEASURED TO AN ADJACENT FACE OF CURB OR TO THE CENTERLINE OF AN ADJACENT PAVEMENT MARKING (AS SHOWN IN THE DRAWINGS).

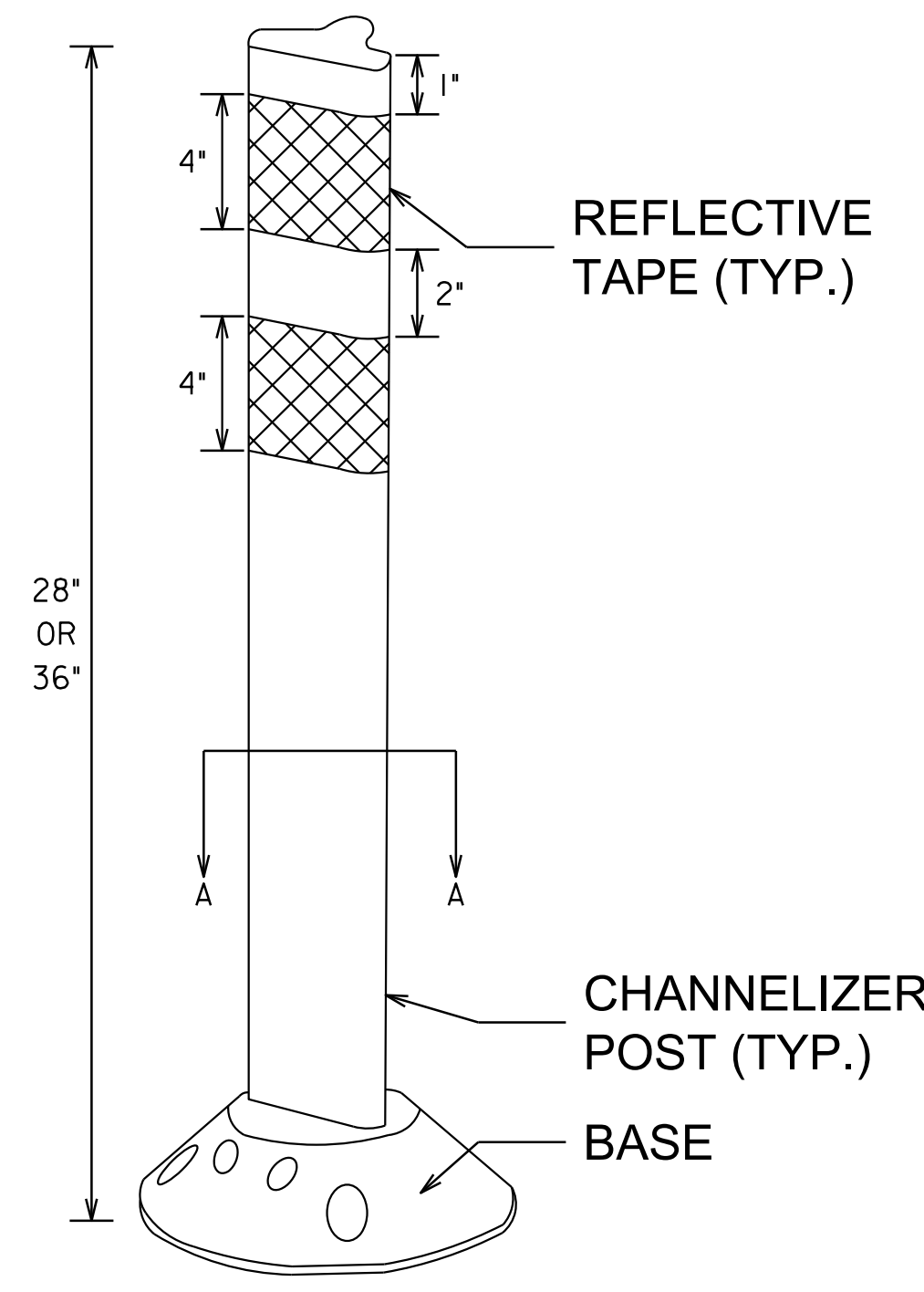
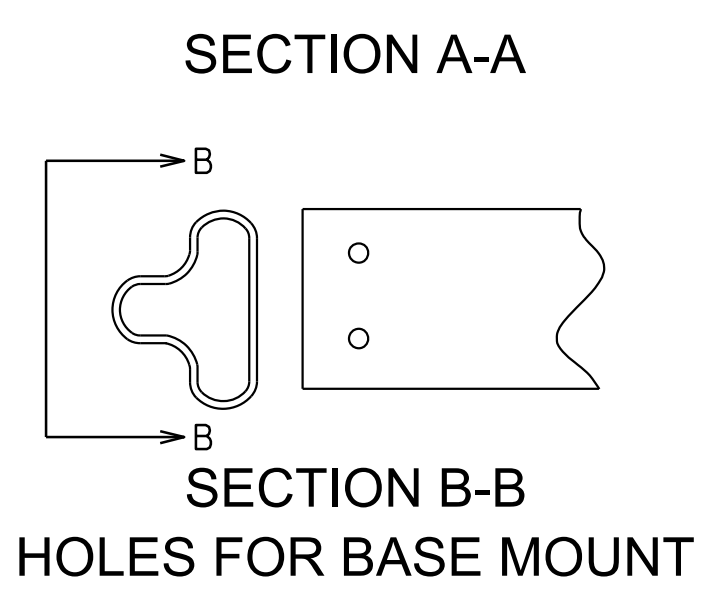
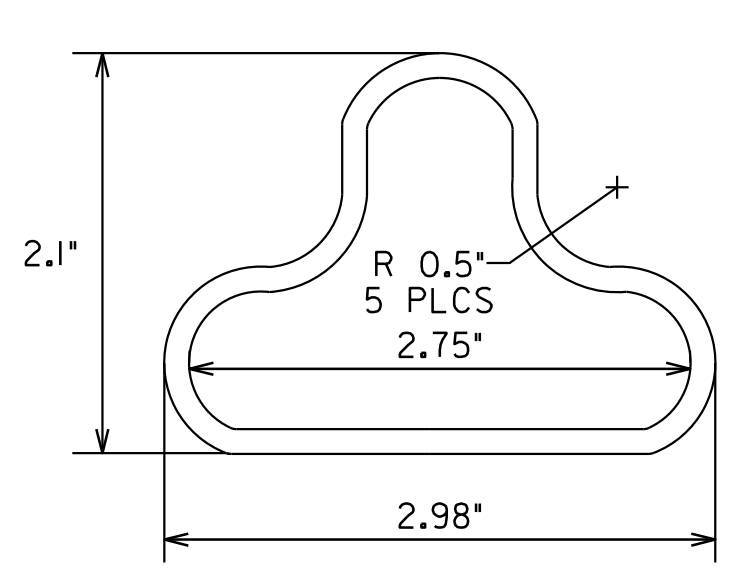
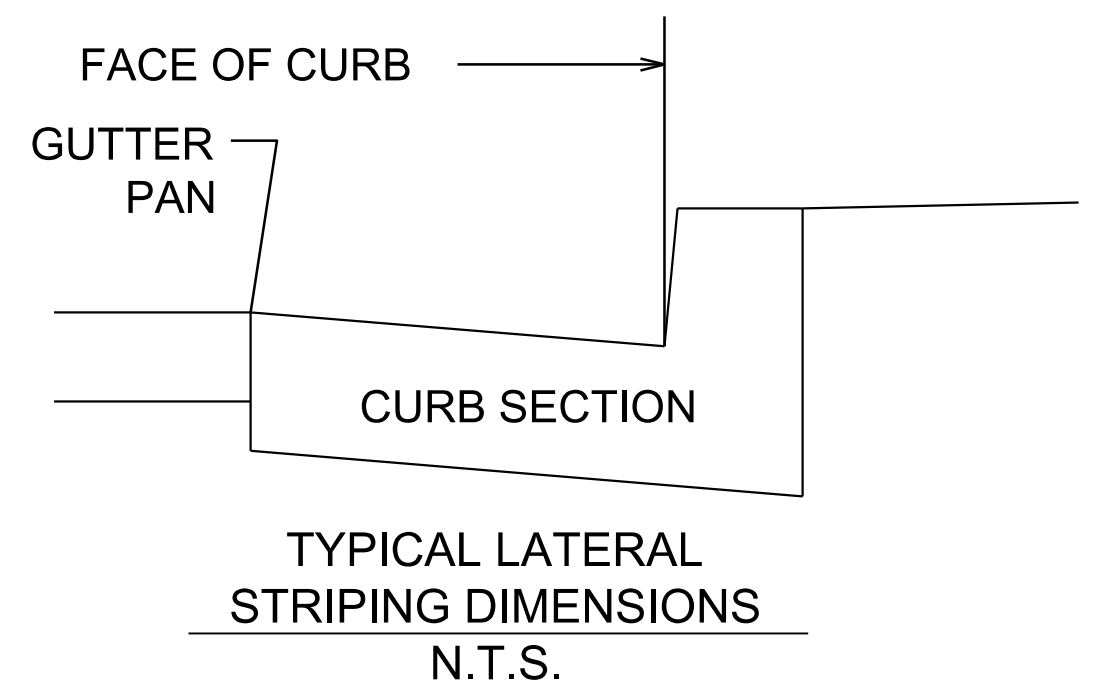

POST IS RETAINED TO BASE WITH 2 PINS
SHOWN WITH TYPICAL REFLECTIVE TAPE APPLIED
28" OR 36" FLEXIBLE CHANNELIZER POST DETAIL
N.T.S.

NOTES:
1. INSTALLATION TO BE COMPLETED IN ACCORDANCE WITH MANUFACTURER'S SPECIFICATIONS.
2. DIMENSIONS, MATERIALS, AND ATTACHMENTS MAY VARY BETWEEN MANUFACTURERS.
3. COLOR OF POST SHALL MATCH COLOR OF APPLICABLE EDGE LINE.
4. FLEXIBLE CHANNELIZER POST SHALL BE INSTALLED IN EACH PRECAST BLOCK GAP.
5. 36" FLEXIBLE CHANNELIZER POST SHALL BE INSTALLED WHERE NOTED ON THE PLANS. ALL OTHERS SHALL BE 28" EXCEPT AS DIRECTED BY THE ENGINEER.

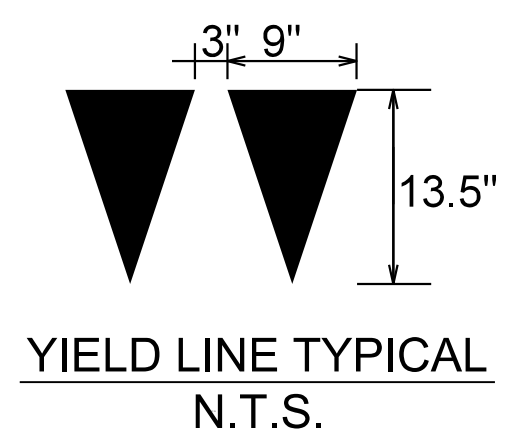
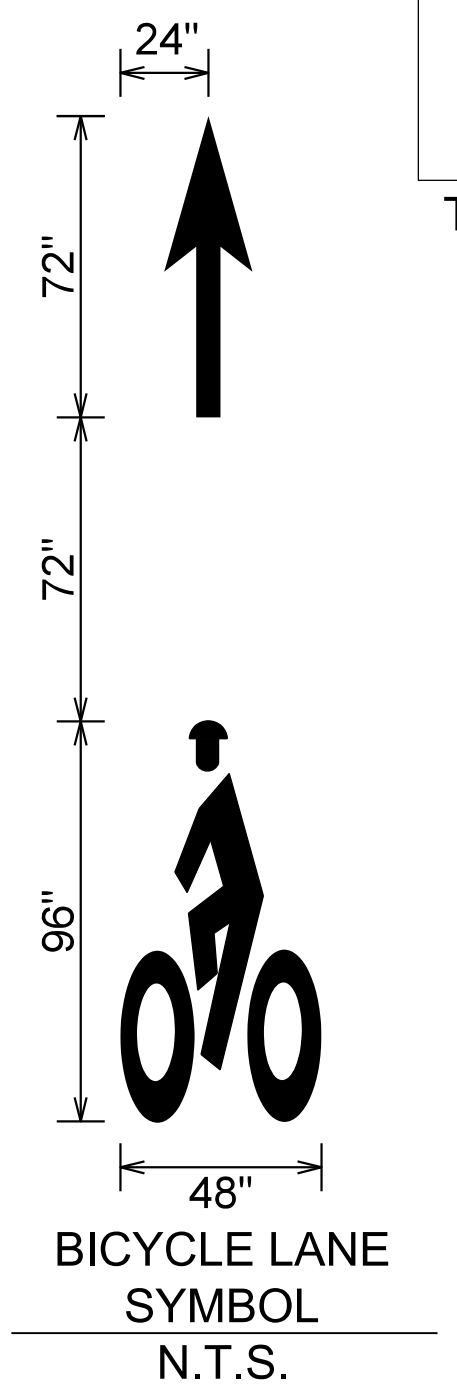
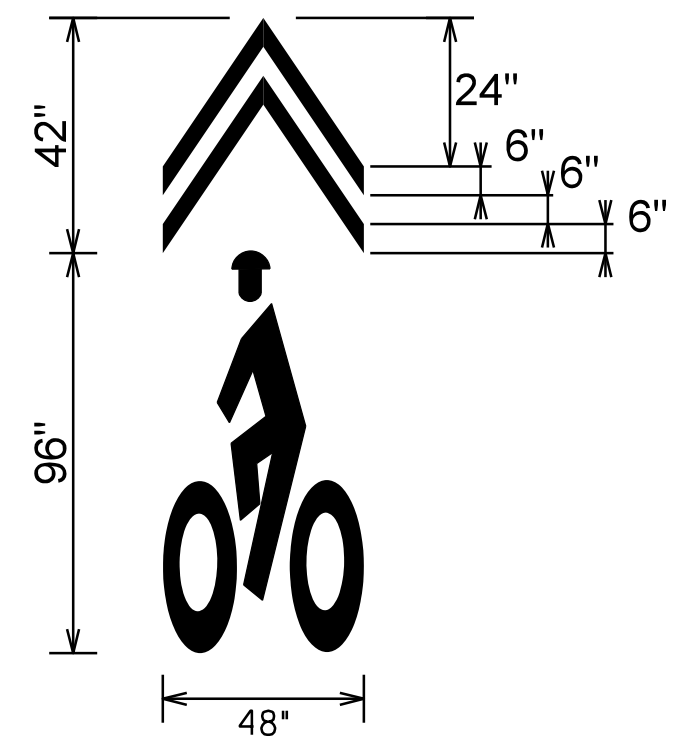
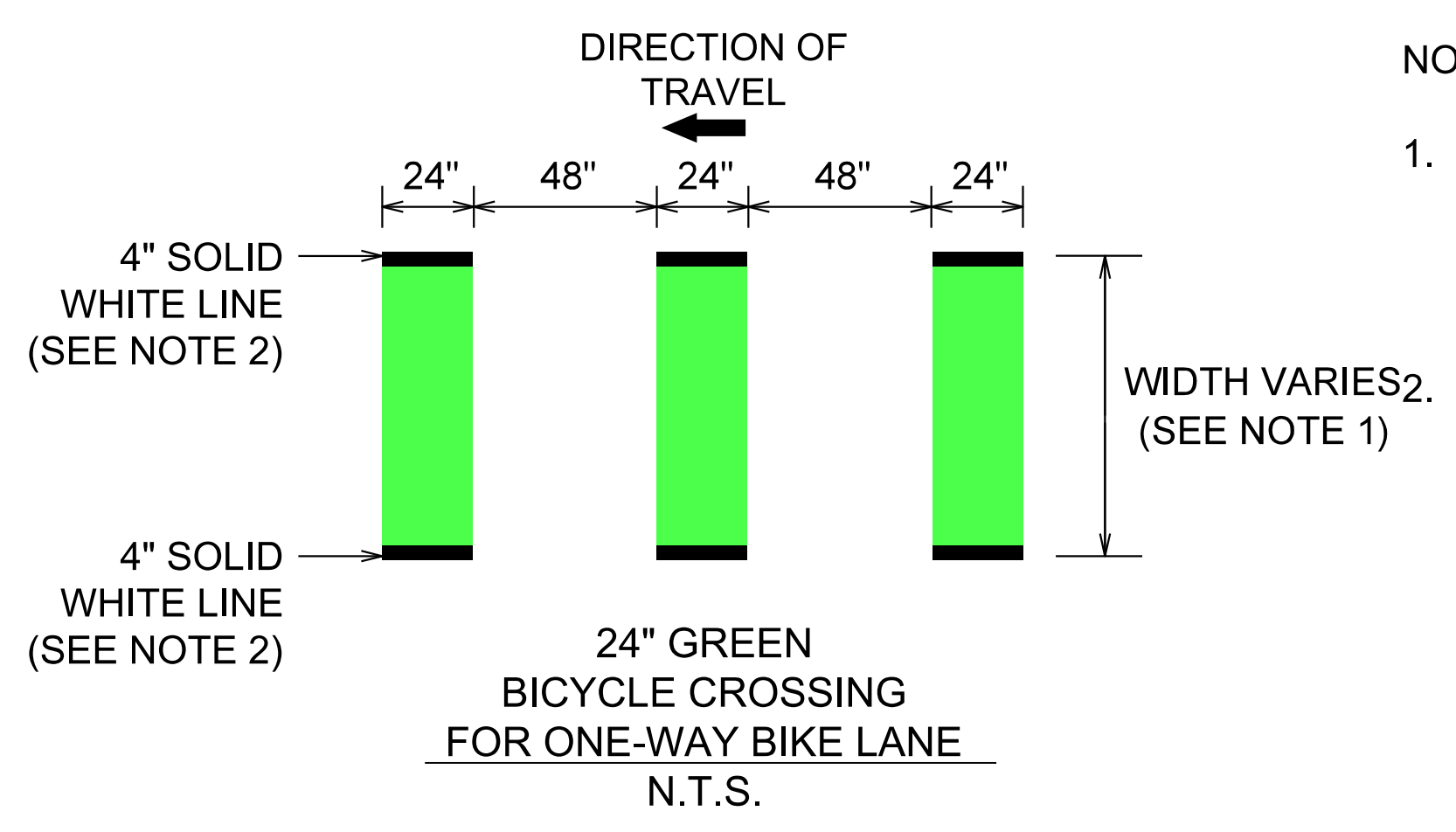

NOTES:
1. ALL MEASUREMENTS TAKEN TO CENTER OF 6" SOLID WHITE LINE. ONE-WAY BIKE LANE WIDTH SHALL BE AS NOTED ON THE SIGNING AND PAVEMENT MARKING PLANS.
WHERE ONE-WAY BIKE LANE IS ADJACENT TO GUTTERPAN AT DRIVEWAYS AND ALLEYS THERE SHALL BE NO 6" SOLID WHITE EDGE LINE. EXTEND GREEN PAINT TO EDGE OF GUTTERPAN. SEE THE SIGNING AND PAVEMENT MARKING PLANS FOR WIDTHS.

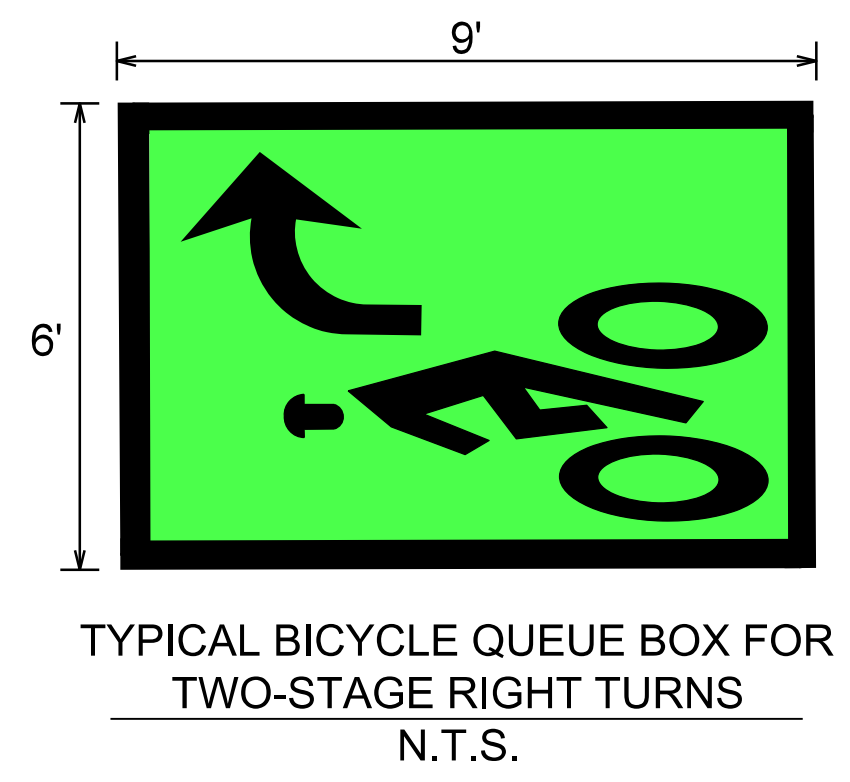
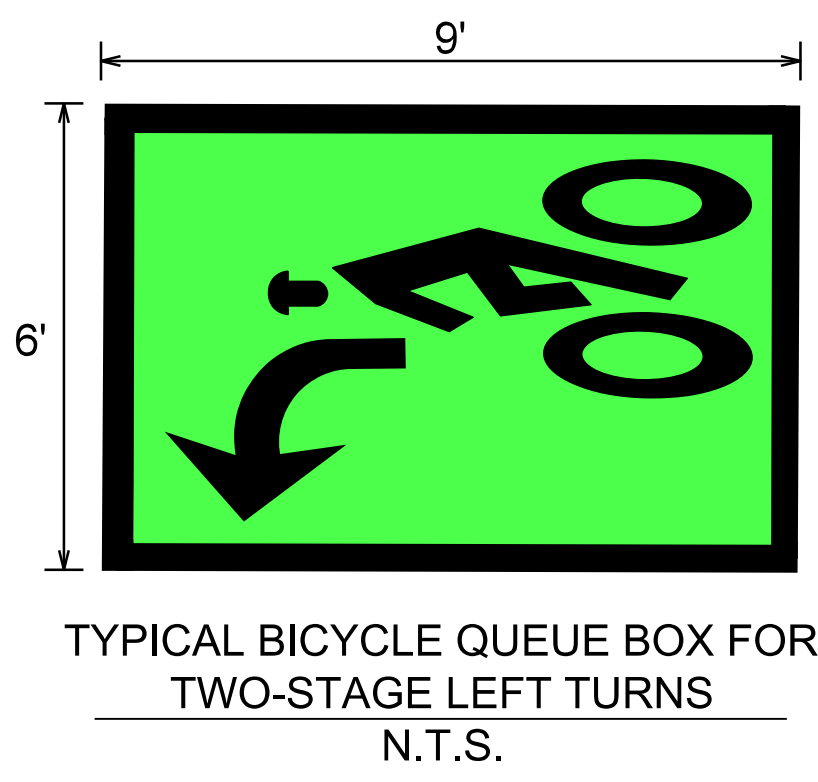
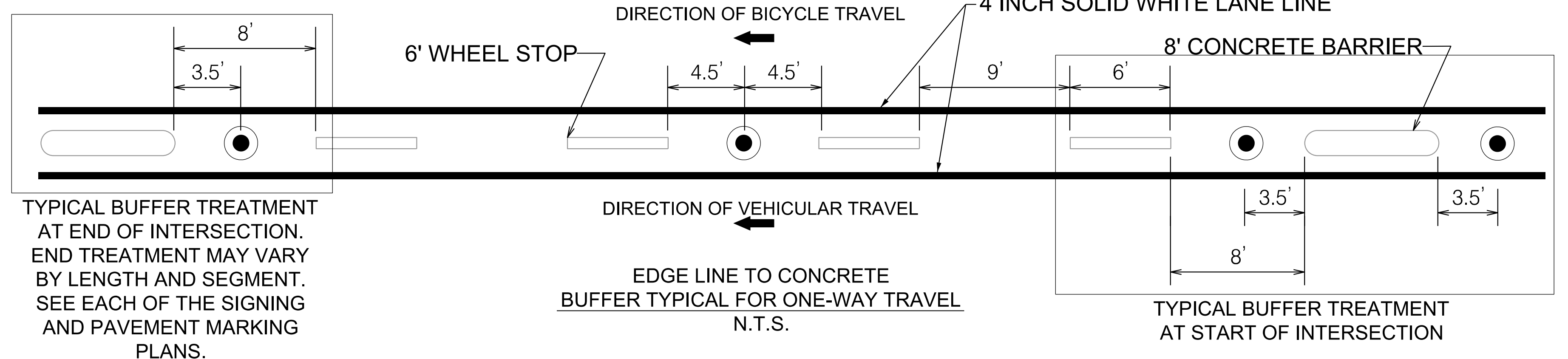
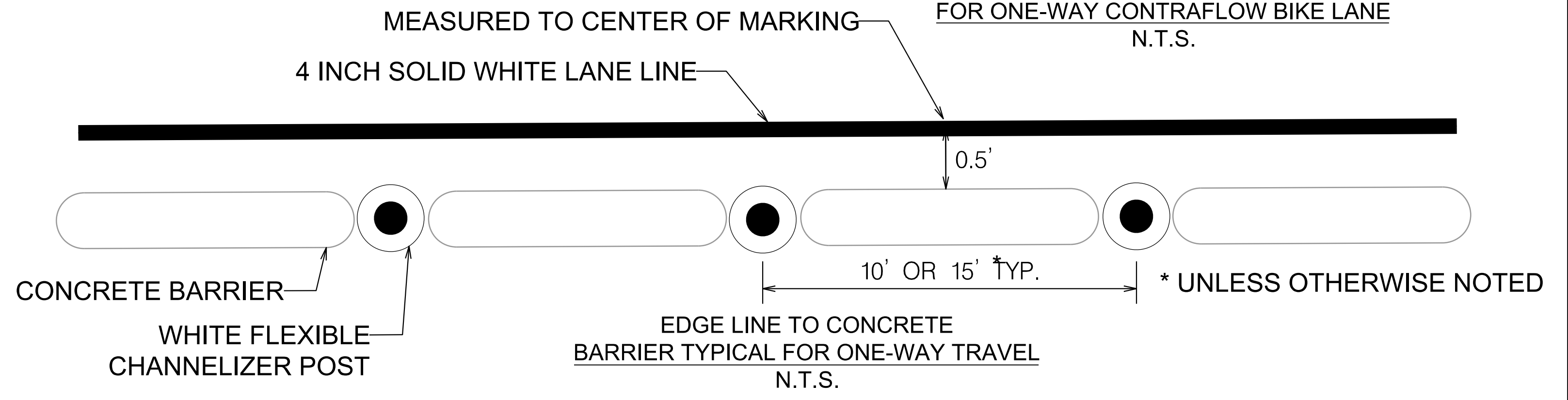
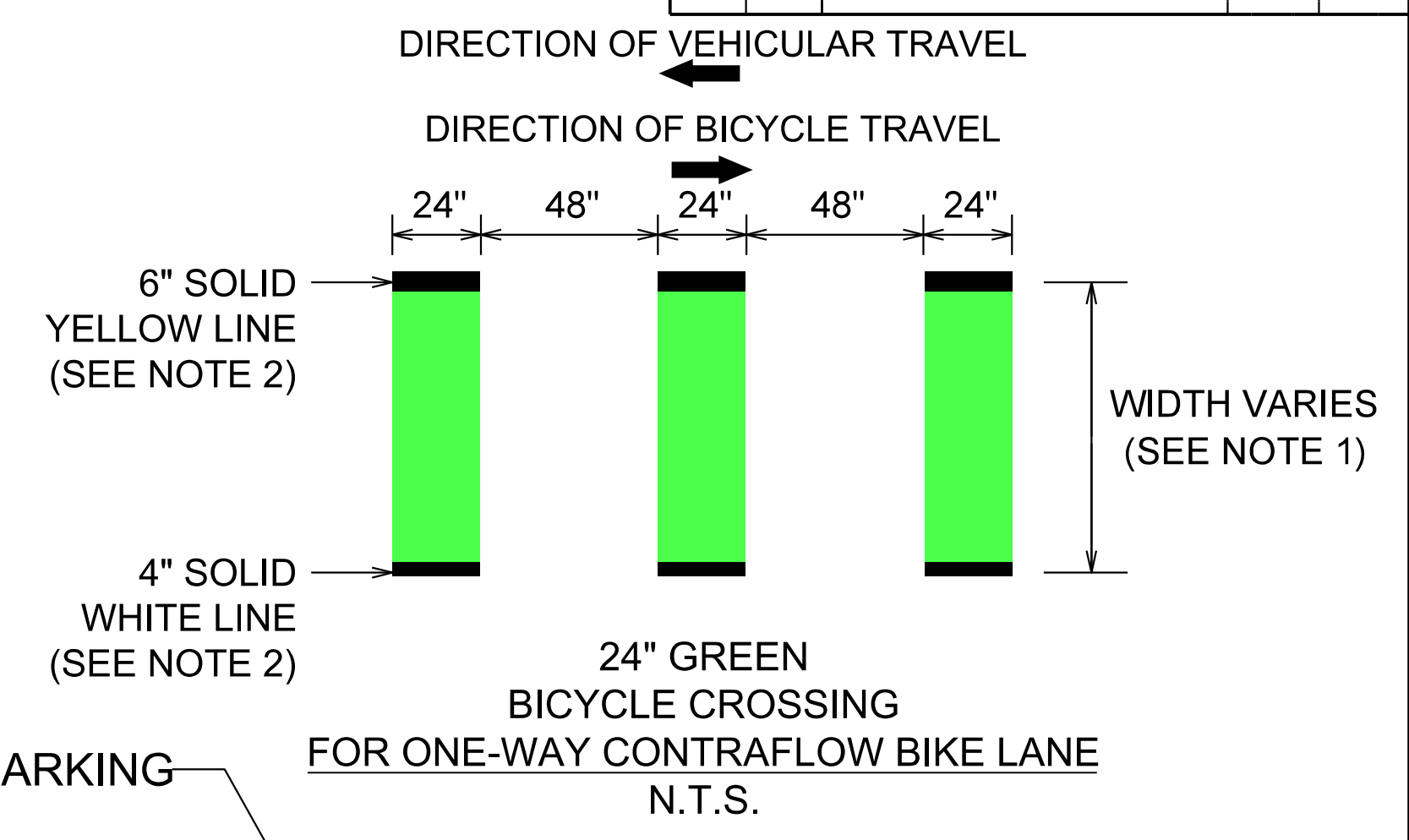

DISTRICT OF COLUMBIA DEPARTMENT OF TRANSPORTATION TRAFFIC ENGINEERING AND SAFETY DIVISION		FINAL
"PARK PLACE 75TH STREET PROTECTED BIKE LANE" FROM GRANT CIRCLE NW TO KENYON STREET NW, PARK ROAD WESTBOUND ONE-WAYING FROM GEORGIA AVENUE NW TO PARK PLACE NW SIGNING AND PAVEMENT MARKING DETAIL-2		FIELD CHECKED BY MP/TK
DESIGNED BY MP		DRAWN BY MP
REVIEWED BY RF		DATE 03 /2022
SCALE NTS		SHEET 47 OF 80
APPROVED: TRAFFIC SIGNAL DIVISION MANAGER /ASSOCIATE DIRECTOR		DRAWING NO. SN-DE2
DATE: _____		

PS&E DESIGN
MARCH 2022
Not for Construction

Mead & Hunt
100 M STREET SE
SUITE 550
WASHINGTON, DC 20003
(202) 570-7080
WWW.MEADHUNT.COM

S.I.F. NO. _____
APPROVED BY _____ DATE _____

3/22/2022 RA\2019\08_BD001 ID10 Traffic Eng_Des_JMT\Task 17 - Park Place_PBL\Drawg\Signing\PSN-D002_Park_Plan.dgn

REG	STATE	PROJECT	SHEET NO.	TOTAL SHEETS
3	D.C.		48	80

DESCRIPTION	REVISION						
	DATE	COR.	CHK.	APP.	APP.	APP.	APP.

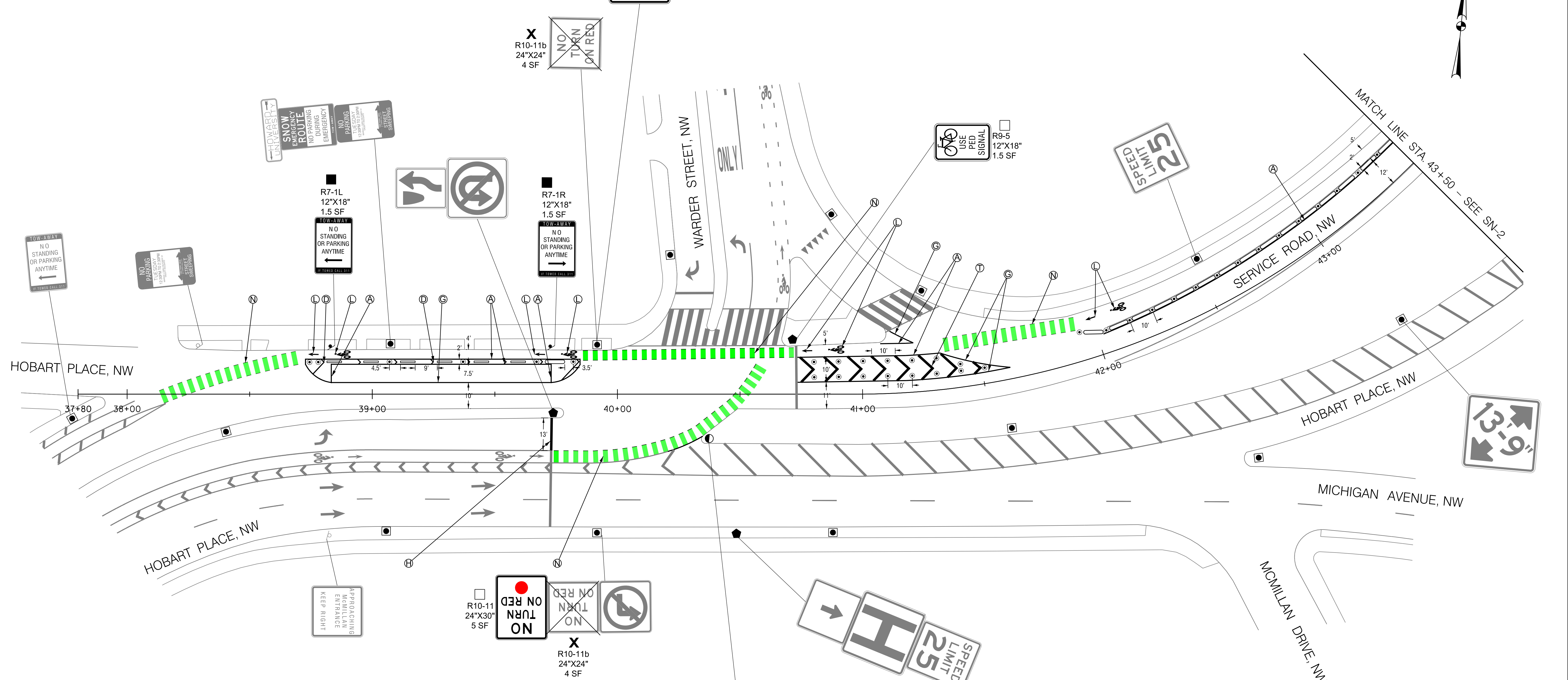

SIGNING LEGEND

ALL EXISTING SIGNS SHALL REMAIN IN PLACE UNLESS OTHERWISE NOTED.

- X EXISTING SIGN TO BE REMOVED
- EXISTING SIGN TO BE RELOCATED
- △ EXISTING SIGN RELOCATED TO EXISTING POST OR EXISTING SIGNAL POLE / LIGHT POLE
- ▲ EXISTING SIGN RELOCATED TO NEW POST
- NEW SIGN TO BE INSTALLED ON EXISTING POST OR EXISTING SIGNAL POLE / LIGHT POLE
- NEW SIGN TO BE INSTALLED ON NEW POST

PAVEMENT MARKING LEGEND

- Ⓐ 4 INCH SOLID WHITE LANE LINE
- Ⓑ 4 INCH DOTTED WHITE LANE LINE (2' STRIPE, 4' SKIP)
- Ⓒ 4 INCH DASHED WHITE LANE LINE (10' STRIPE, 30' SKIP)
- Ⓓ GORE MARKINGS WITH 4 INCH SOLID WHITE LINES (15' O.C. AT 45 DEGREES)
- Ⓔ DIAGONAL MARKINGS 4 INCH SOLID WHITE LINES (5' O.C. AT 45 DEGREES)
- Ⓕ DIAGONAL MARKINGS 4 INCH SOLID WHITE LINES (7.5' O.C. AT 45 DEGREES)
- Ⓖ 6 INCH SOLID WHITE LANE LINE
- Ⓗ 12 INCH WHITE STOP BAR
- Ⓙ 24 INCH WHITE CROSSWALK STRIPE
- Ⓚ 4 INCH DOUBLE SOLID YELLOW LANE LINE
- Ⓛ WHITE BICYCLE LANE SYMBOL OR ARROW
- Ⓜ GREEN COLORED PAVEMENT WITH 4 INCH LANE LINE BORDER
- Ⓝ 24" GREEN BICYCLE CROSSING FOR ONE WAY BIKE LANE (SEE DETAIL ON SHEET SN-DE2)
- Ⓟ DIAGONAL MARKINGS 4 INCH SOLID YELLOW LINES(15' O.C. AT 45 DEGREES)
- Ⓠ YIELD LINE SYMBOL
- Ⓡ WHITE SHARROWS
- Ⓢ DIAGONAL MARKINGS 12 INCH SOLID WHITE LINES (15' O.C. AT 45 DEGREES)
- Ⓣ GORE MARKINGS WITH 12 INCH SOLID WHITE LINES (10' O.C. AT 45 DEGREES)

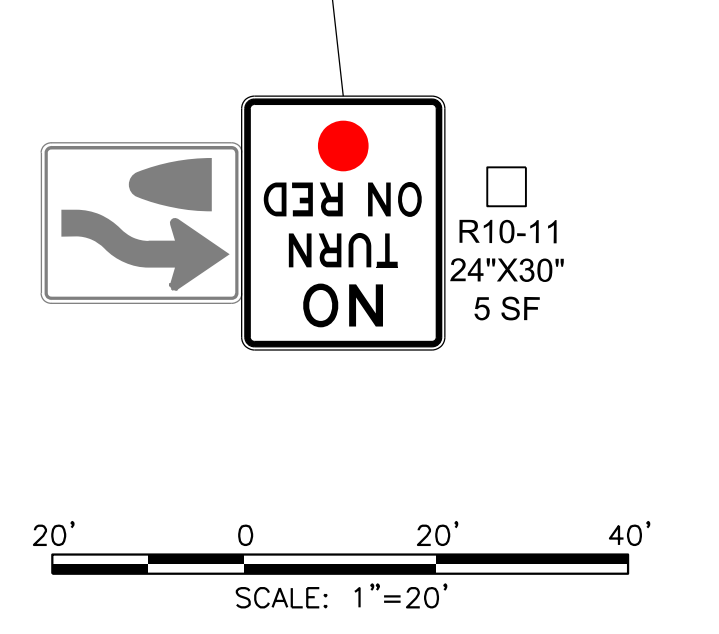

Mead & Hunt
 100 M STREET SE SUITE 550
 WASHINGTON, DC 20003
 (202) 570-7080
 WWW.MEADHUNT.COM

S.I.F. NO. _____
 APPROVED BY _____ DATE _____

PS&E DESIGN
 MARCH 2022
 Not for Construction

DISTRICT OF COLUMBIA DEPARTMENT OF TRANSPORTATION TRAFFIC ENGINEERING AND SAFETY DIVISION		FINAL
PARK PLACE /5TH STREET – PROTECTED BIKE LANE FROM HOBART PLACE NW TO GRANT CIRCLE NW, PARK ROAD WESTBOUND ONE-WAYING FROM PARK PLACE NW TO GEORGIA AVENUE NW SIGNING AND PAVEMENT MARKING		FIELD CHECKED BY MP/TK
DESIGNED BY MP	DRAWN BY MP	REVIEWED BY RF
RECOMMENDED FOR APPROVAL: TRAFFIC SIGNAL DESIGN ENGINEER _____ TRAFFIC SIGNAL PROGRAM MANAGER _____ APPROVED: TRAFFIC SIGNAL DIVISION MANAGER /ASSOCIATE DIRECTOR _____ DATE: _____		DATE 03 /2022 SCALE 1" = 20' SHEET 48 OF 80 DRAWING NO. SN-1

3/22/2022 RA:\2019\08_001\Traffic Eng_Design\Task 17 - Park Place_PBL\Drawings\Signing\PSN-001_Park PI NW.dgn

REG	STATE	PROJECT	SHEET NO.	TOTAL SHEETS
3	D.C.		49	80

DESCRIPTION	REVISION						
	DATE	COR.	CHK.	APP.	APP.	APP.	APP.

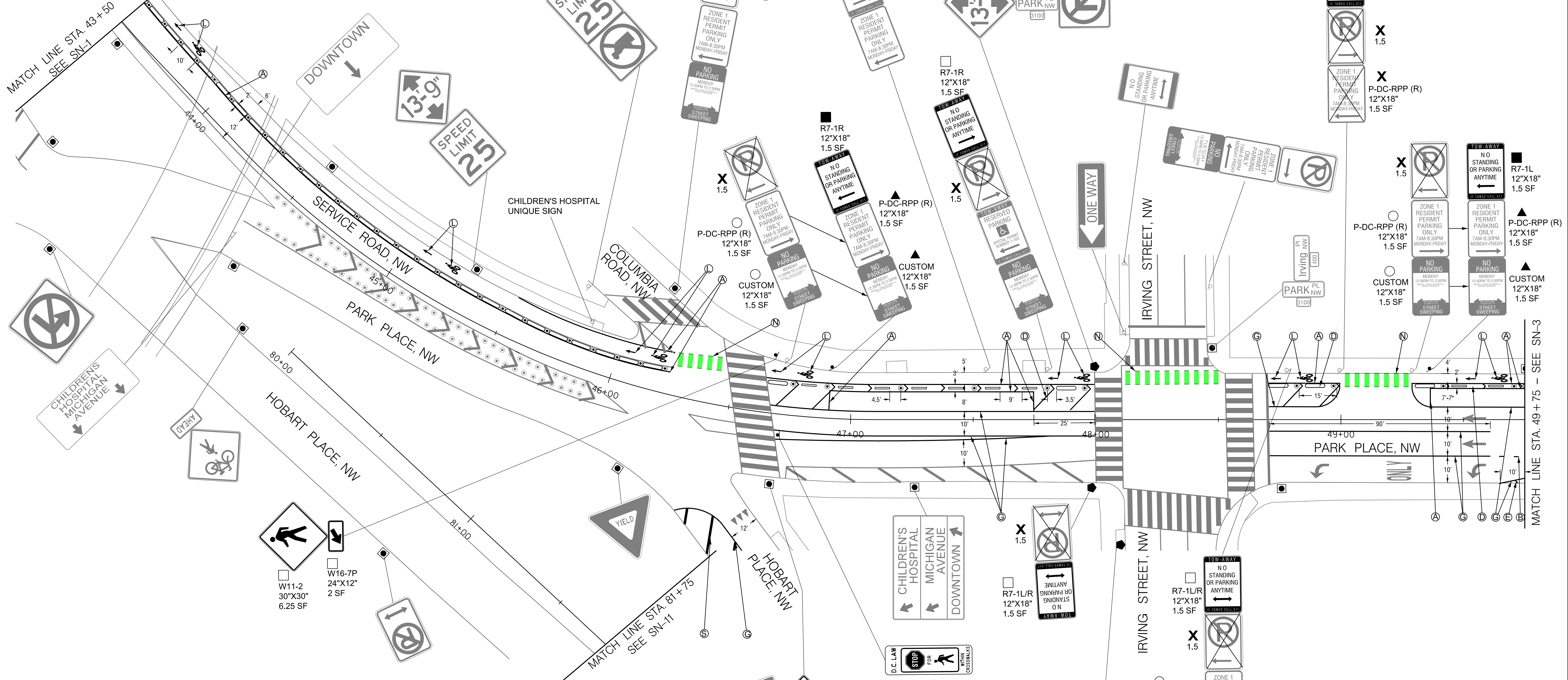

SIGNING LEGEND

ALL EXISTING SIGNS SHALL REMAIN IN PLACE UNLESS OTHERWISE NOTED.

- X EXISTING SIGN TO BE REMOVED
- O EXISTING SIGN TO BE RELOCATED
- △ EXISTING SIGN RELOCATED TO EXISTING POST OR EXISTING SIGNAL POLE / LIGHT POLE
- ▲ EXISTING SIGN RELOCATED TO NEW POST
- NEW SIGN TO BE INSTALLED ON EXISTING POST OR EXISTING SIGNAL POLE / LIGHT POLE
- NEW SIGN TO BE INSTALLED ON NEW POST

PAVEMENT MARKING LEGEND

- A 4 INCH SOLID WHITE LANE LINE
- B 4 INCH DOTTED WHITE LANE LINE (2' STRIPE, 4' SKIP)
- C 4 INCH DASHED WHITE LANE LINE (10' STRIPE, 30' SKIP)
- D GORE MARKINGS WITH 4 INCH SOLID WHITE LINES (15' O.C. AT 45 DEGREES)
- E DIAGONAL MARKINGS 4 INCH SOLID WHITE LINES (5' O.C. AT 45 DEGREES)
- F DIAGONAL MARKINGS 4 INCH SOLID WHITE LINES (7.5' O.C. AT 45 DEGREES)
- G 6 INCH SOLID WHITE LANE LINE
- H 12 INCH WHITE STOP BAR
- I 24 INCH WHITE CROSSWALK STRIPE
- J 4 INCH DOUBLE SOLID YELLOW LANE LINE
- K WHITE BICYCLE LANE SYMBOL OR ARROW
- L GREEN COLORED PAVEMENT WITH 4 INCH LANE LINE BORDER
- M 24" GREEN BICYCLE CROSSING FOR ONE WAY BIKE LANE (SEE DETAIL ON SHEET SN-DE2)
- N DIAGONAL MARKINGS 4 INCH SOLID YELLOW LINES(15' O.C. AT 45 DEGREES)
- O YIELD LINE SYMBOL
- P WHITE SHARROWS
- Q DIAGONAL MARKINGS 12 INCH SOLID WHITE LINES (15' O.C. AT 45 DEGREES)
- R GORE MARKINGS WITH 12 INCH SOLID WHITE LINES (10' O.C. AT 45 DEGREES)

W11-2 30"x30" 6.25 SF

W16-7P 24"x12" 2 SF

R1-6a MOD 12"x36" 2.5 SF

Scale: 1" = 20'

Mead & Hunt
100 M STREET SE SUITE 550 WASHINGTON, DC 20003 (202) 570-7080 WWW.MEADHUNT.COM

S.I.F. NO. _____

APPROVED BY _____ DATE _____

PS&E DESIGN MARCH 2022
Not for Construction

DISTRICT OF COLUMBIA DEPARTMENT OF TRANSPORTATION TRAFFIC ENGINEERING AND SAFETY DIVISION		FINAL
PARK PLACE /5TH STREET - PROTECTED BIKE LANE FROM HOBART PLACE NW TO GRANT CIRCLE NW, PARK ROAD WESTBOUND ONE-WAYING FROM PARK PLACE NW TO GEORGIA AVENUE NW SIGNING AND PAVEMENT MARKING		FIELD CHECKED BY MP/TK
DESIGNED BY MP	DRAWN BY MP	REVIEWED BY RF
RECOMMENDED FOR APPROVAL:	DATE 03 /2022	SCALE 1" = 20'
TRAFFIC SIGNAL DESIGN ENGINEER _____	DATE _____	SHEET 49 OF 80
TRAFFIC SIGNAL PROGRAM MANAGER _____	DATE _____	DRAWING NO. SN-2
APPROVED:	DATE _____	
TRAFFIC SIGNAL DIVISION MANAGER /ASSOCIATE DIRECTOR _____		

3/22/2022 RA\2019\08_0001 ID10 Traffic Eng_Design\Task 17 - Park Place_PBL\Drawings\Signing\PSN-002_Park Pl_NW.dgn

DESCRIPTION	REVISION						
	DATE	COR.	CHK.	APP.	APP.	APP.	APP.

REG	STATE	PROJECT	SHEET NO.	TOTAL SHEETS
3	D.C.		50	80

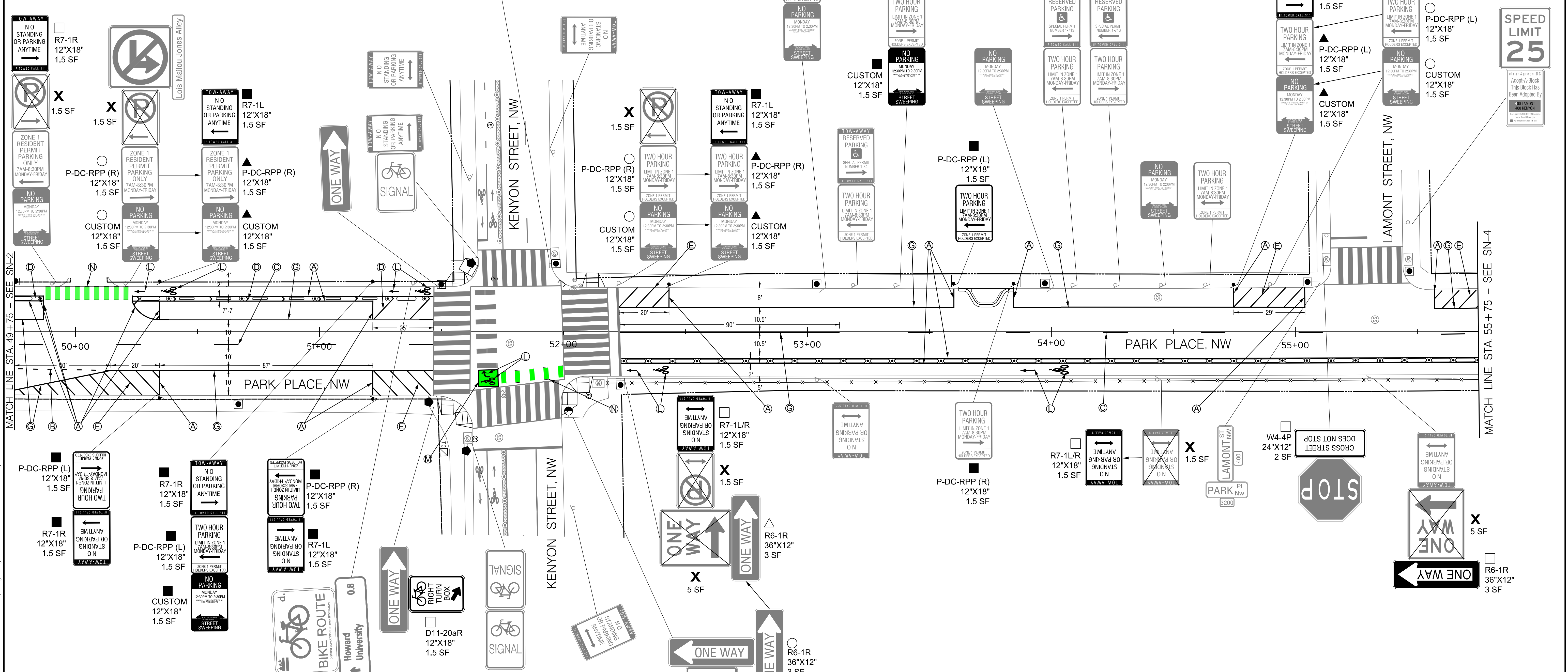

SIGNING LEGEND

ALL EXISTING SIGNS SHALL REMAIN IN PLACE UNLESS OTHERWISE NOTED.

- X EXISTING SIGN TO BE REMOVED
- O EXISTING SIGN TO BE RELOCATED
- △ EXISTING SIGN RELOCATED TO EXISTING POST OR EXISTING SIGNAL POLE / LIGHT POLE
- ▲ EXISTING SIGN RELOCATED TO NEW POST
- NEW SIGN TO BE INSTALLED ON EXISTING POST OR EXISTING SIGNAL POLE / LIGHT POLE
- NEW SIGN TO BE INSTALLED ON NEW POST

PAVEMENT MARKING LEGEND

- Ⓐ 4 INCH SOLID WHITE LANE LINE
- Ⓑ 4 INCH DOTTED WHITE LANE LINE (2' STRIPE, 4' SKIP)
- Ⓒ 4 INCH DASHED WHITE LANE LINE (10' STRIPE, 30' SKIP)
- Ⓓ GORE MARKINGS WITH 4 INCH SOLID WHITE LINES (15' O.C. AT 45 DEGREES)
- Ⓔ DIAGONAL MARKINGS 4 INCH SOLID WHITE LINES (5' O.C. AT 45 DEGREES)
- Ⓕ DIAGONAL MARKINGS 4 INCH SOLID WHITE LINES (7.5' O.C. AT 45 DEGREES)
- Ⓖ 6 INCH SOLID WHITE LANE LINE
- Ⓗ 12 INCH WHITE STOP BAR
- Ⓙ 24 INCH WHITE CROSSWALK STRIPE
- Ⓚ 4 INCH DOUBLE SOLID YELLOW LANE LINE
- Ⓛ WHITE BICYCLE LANE SYMBOL OR ARROW
- Ⓜ GREEN COLORED PAVEMENT WITH 4 INCH LANE LINE BORDER
- Ⓝ 24" GREEN BICYCLE CROSSING FOR ONE WAY BIKE LANE (SEE DETAIL ON SHEET SN-DE2)
- Ⓟ DIAGONAL MARKINGS 4 INCH SOLID YELLOW LINES(15' O.C. AT 45 DEGREES)
- Ⓠ YIELD LINE SYMBOL
- Ⓡ WHITE SHARROWS
- Ⓢ DIAGONAL MARKINGS 12 INCH SOLID WHITE LINES (15' O.C. AT 45 DEGREES)
- Ⓣ GORE MARKINGS WITH 12 INCH SOLID WHITE LINES (10' O.C. AT 45 DEGREES)

SCALE: 1" = 20'

Mead & Hunt
100 M STREET SE SUITE 550
WASHINGTON, DC 20003
(202) 570-7080
WWW.MEADHUNT.COM

S.I.F. NO. _____
APPROVED BY _____ DATE _____

DISTRICT OF COLUMBIA
DEPARTMENT OF TRANSPORTATION
TRAFFIC ENGINEERING AND SAFETY DIVISION

PARK PLACE /5TH STREET – PROTECTED BIKE LANE
FROM HOBART PLACE NW TO GRANT CIRCLE NW,
PARK ROAD WESTBOUND ONE-WAYING
FROM PARK PLACE NW TO GEORGIA AVENUE NW
SIGNING AND PAVEMENT MARKING

RECOMMENDED FOR APPROVAL:	FINAL
TRAFFIC SIGNAL DESIGN ENGINEER	FIELD CHECKED BY
TRAFFIC SIGNAL PROGRAM MANAGER	MP/TK
APPROVED:	DESIGNED BY
TRAFFIC SIGNAL DIVISION MANAGER /ASSOCIATE DIRECTOR	MP
DATE: _____	REVIEWED BY
	RF
	DATE
	03 /2022
	SCALE
	1" = 20'
	SHEET
	50 OF 80
	DRAWING NO.
	SN-3

PS&E DESIGN
MARCH 2022
Not for Construction

3/22/2022 RA:2019.08 DD01 ID:0 Traffic Eng. Des. JMT\Task 17 - Park Place_PBL\Draw\Signing\SN-003_Park Pl. NW.dgn

DESCRIPTION	REVISION						
	DATE	COR.	CHK.	APP.	APP.	APP.	APP.

REG	STATE	PROJECT	SHEET NO.	TOTAL SHEETS
3	D.C.		51	80

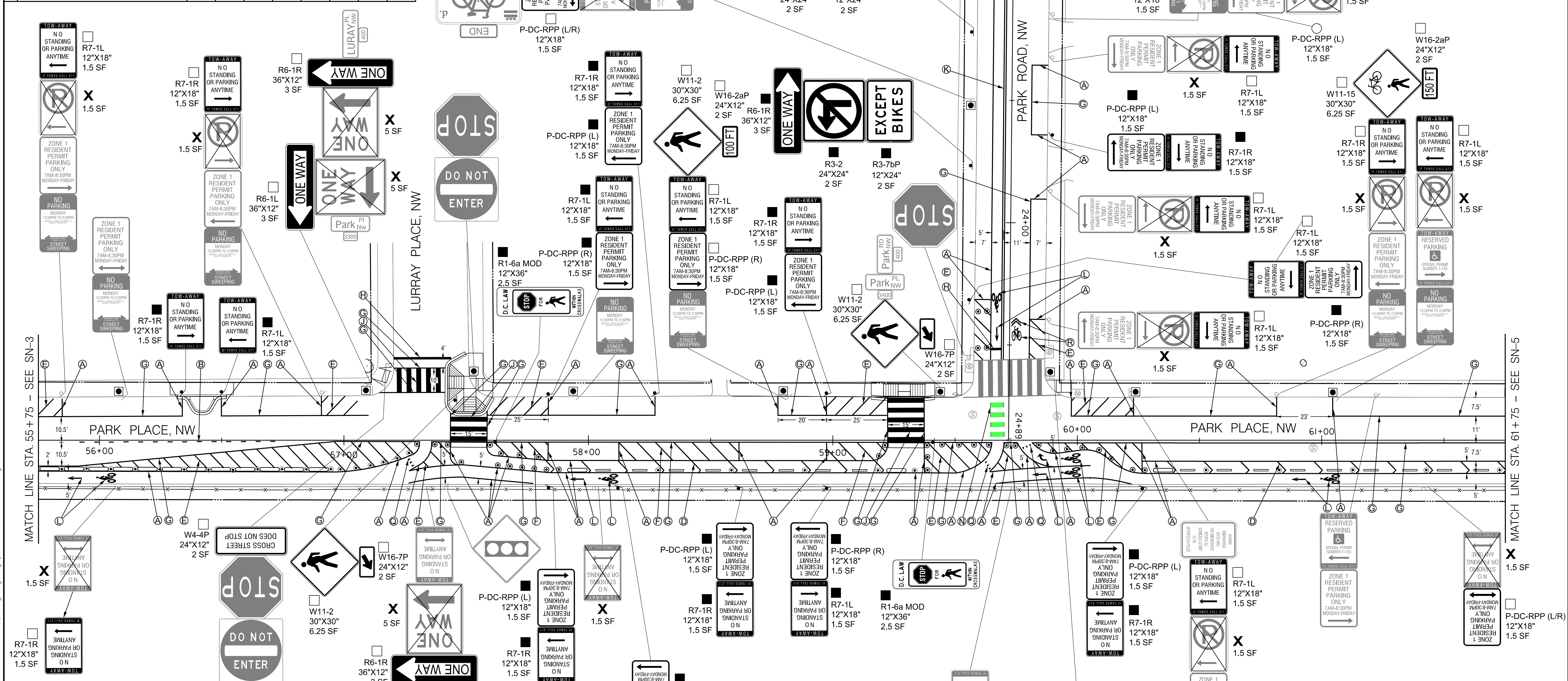

SIGNING LEGEND

ALL EXISTING SIGNS SHALL REMAIN IN PLACE UNLESS OTHERWISE NOTED.

- X EXISTING SIGN TO BE REMOVED
- EXISTING SIGN TO BE RELOCATED
- △ EXISTING SIGN RELOCATED TO EXISTING POST OR EXISTING SIGNAL POLE / LIGHT POLE
- ▲ EXISTING SIGN RELOCATED TO NEW POST
- NEW SIGN TO BE INSTALLED ON EXISTING POST OR EXISTING SIGNAL POLE / LIGHT POLE
- NEW SIGN TO BE INSTALLED ON NEW POST

PAVEMENT MARKING LEGEND

- Ⓐ 4 INCH SOLID WHITE LANE LINE
- Ⓑ 4 INCH DOTTED WHITE LANE LINE (2' STRIPE, 4' SKIP)
- Ⓒ 4 INCH DASHED WHITE LANE LINE (10' STRIPE, 30' SKIP)
- Ⓓ GORE MARKINGS WITH 4 INCH SOLID WHITE LINES (15' O.C. AT 45 DEGREES)
- Ⓔ DIAGONAL MARKINGS 4 INCH SOLID WHITE LINES (5' O.C. AT 45 DEGREES)
- Ⓕ DIAGONAL MARKINGS 4 INCH SOLID WHITE LINES (7.5' O.C. AT 45 DEGREES)
- Ⓖ 6 INCH SOLID WHITE LANE LINE
- Ⓗ 12 INCH WHITE STOP BAR
- Ⓙ 24 INCH WHITE CROSSWALK STRIPE
- Ⓚ 4 INCH DOUBLE SOLID YELLOW LANE LINE
- Ⓛ WHITE BICYCLE LANE SYMBOL OR ARROW
- Ⓜ GREEN COLORED PAVEMENT WITH 4 INCH LANE LINE BORDER
- Ⓝ 24" GREEN BICYCLE CROSSING FOR ONE WAY BIKE LANE (SEE DETAIL ON SHEET SN-DE2)
- Ⓟ DIAGONAL MARKINGS 4 INCH SOLID YELLOW LINES (15' O.C. AT 45 DEGREES)
- Ⓠ YIELD LINE SYMBOL
- Ⓡ WHITE SHARROWS
- Ⓢ DIAGONAL MARKINGS 12 INCH SOLID WHITE LINES (15' O.C. AT 45 DEGREES)
- Ⓣ GORE MARKINGS WITH 12 INCH SOLID WHITE LINES (10' O.C. AT 45 DEGREES)

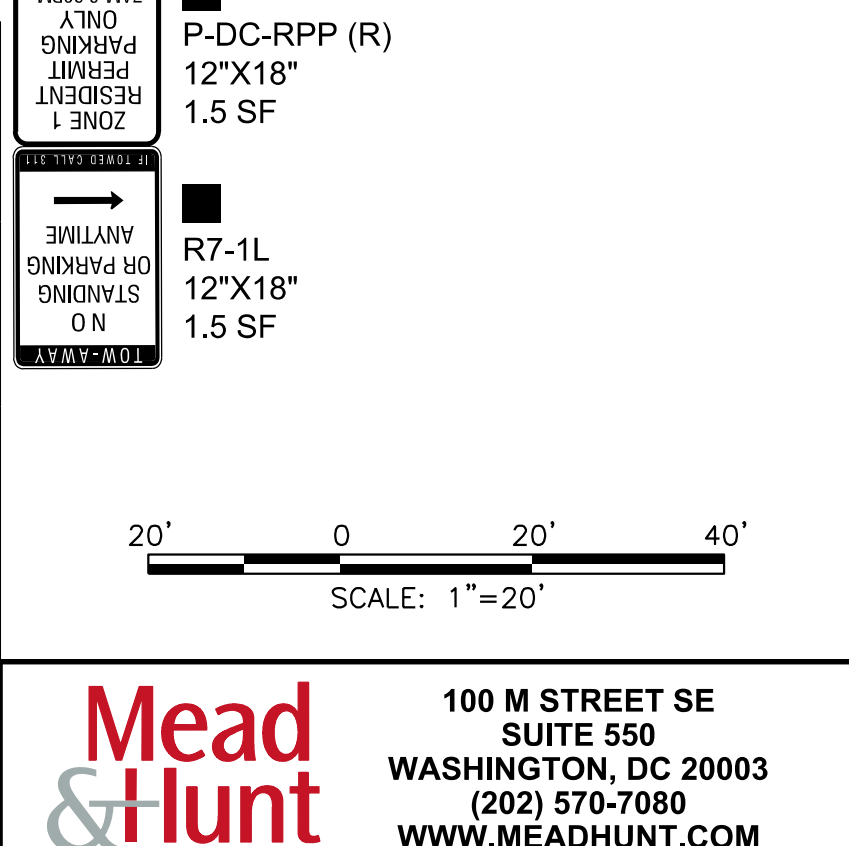

Begin	End	Value
Columbia Hts	0.5	
Georgia Ave/ Petworth M	0.8	
Mt Pleasant	1.2	

DISTRICT OF COLUMBIA
DEPARTMENT OF TRANSPORTATION
TRAFFIC ENGINEERING AND SAFETY DIVISION

PARK PLACE /5TH STREET – PROTECTED BIKE LANE FROM HOBART PLACE NW TO GRANT CIRCLE NW, PARK ROAD WESTBOUND ONE-WAY FROM PARK PLACE NW TO GEORGIA AVENUE NW SIGNING AND PAVEMENT MARKING

RECOMMENDED FOR APPROVAL:	DATE: 03 / 2022
TRAFFIC SIGNAL DESIGN ENGINEER	SCALE: 1" = 20'
TRAFFIC SIGNAL PROGRAM MANAGER	SHEET 51 OF 80
APPROVED:	DRAWING NO. SN-4
TRAFFIC SIGNAL DIVISION MANAGER / ASSOCIATE DIRECTOR	

PS&E DESIGN
MARCH 2022
Not for Construction

3/22/2022 RA:2019\08_0001 ID:0 Traffic Eng_Design_JMT\Task 17 - Park Place_PBL\Drawings\SN-004_Park Pl_NW.dgn

DESCRIPTION	REVISION						
	DATE	COR.	CHK.	APP.	APP.	APP.	APP.

REG	STATE	PROJECT	SHEET NO.	TOTAL SHEETS
3	D.C.		52	80

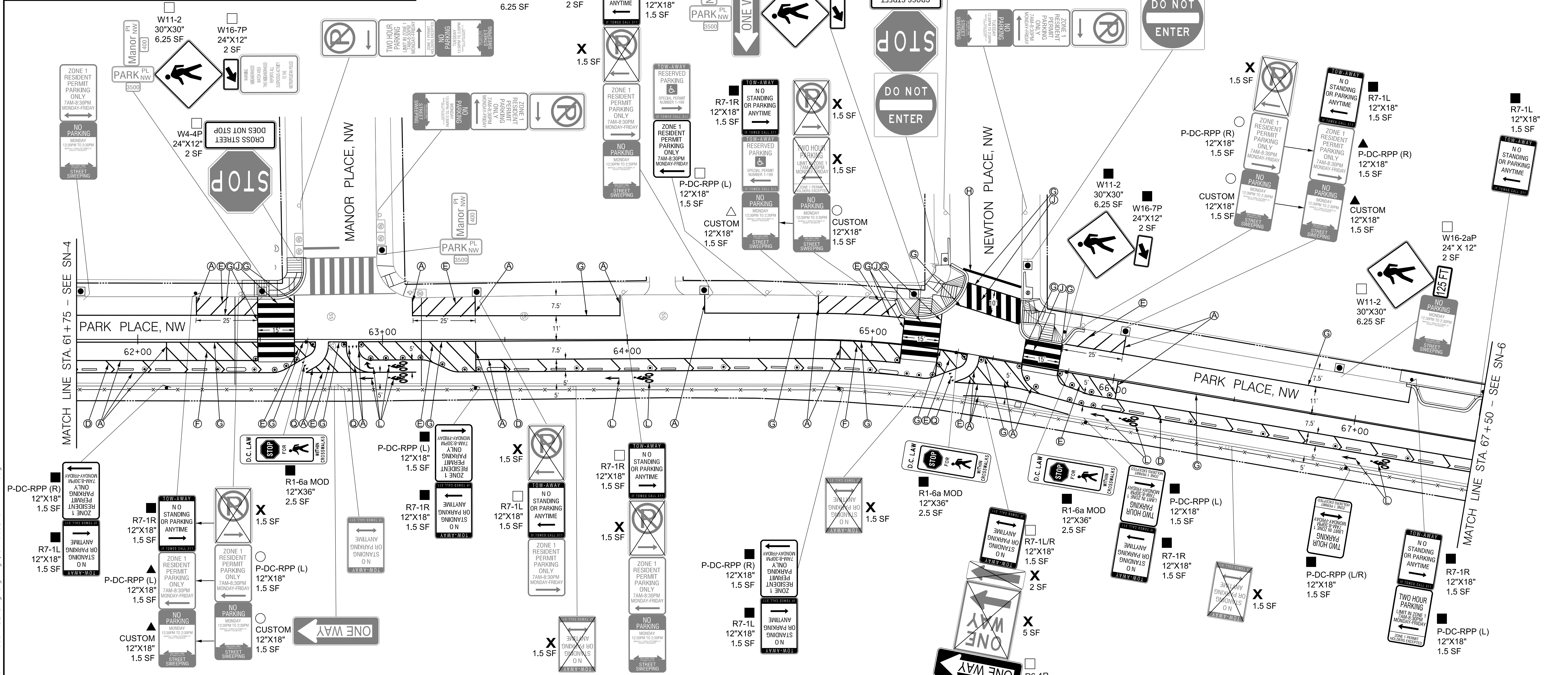

SIGNING LEGEND

- ALL EXISTING SIGNS SHALL REMAIN IN PLACE UNLESS OTHERWISE NOTED.
- X EXISTING SIGN TO BE REMOVED
 - EXISTING SIGN TO BE RELOCATED
 - △ EXISTING SIGN RELOCATED TO EXISTING POST OR EXISTING SIGNAL POLE / LIGHT POLE
 - ▲ EXISTING SIGN RELOCATED TO NEW POST
 - NEW SIGN TO BE INSTALLED ON EXISTING POST OR EXISTING SIGNAL POLE / LIGHT POLE
 - NEW SIGN TO BE INSTALLED ON NEW POST

PAVEMENT MARKING LEGEND

- Ⓐ 4 INCH SOLID WHITE LANE LINE
- Ⓑ 4 INCH DOTTED WHITE LANE LINE (2' STRIPE, 4' SKIP)
- Ⓒ 4 INCH DASHED WHITE LANE LINE (10' STRIPE, 30' SKIP)
- Ⓓ GORE MARKINGS WITH 4 INCH SOLID WHITE LINES (15' O.C. AT 45 DEGREES)
- Ⓔ DIAGONAL MARKINGS 4 INCH SOLID WHITE LINES (5' O.C. AT 45 DEGREES)
- Ⓕ DIAGONAL MARKINGS 4 INCH SOLID WHITE LINES (7.5' O.C. AT 45 DEGREES)
- Ⓖ 6 INCH SOLID WHITE LANE LINE
- Ⓗ 12 INCH WHITE STOP BAR
- Ⓙ 24 INCH WHITE CROSSWALK STRIPE
- Ⓚ 4 INCH DOUBLE SOLID YELLOW LANE LINE
- Ⓛ WHITE BICYCLE LANE SYMBOL OR ARROW
- Ⓜ GREEN COLORED PAVEMENT WITH 4 INCH LANE LINE BORDER
- Ⓝ 24" GREEN BICYCLE CROSSING FOR ONE WAY BIKE LANE (SEE DETAIL ON SHEET SN-DE2)
- Ⓟ DIAGONAL MARKINGS 4 INCH SOLID YELLOW LINES (15' O.C. AT 45 DEGREES)
- Ⓠ YIELD LINE SYMBOL
- Ⓡ WHITE SHARROWS
- Ⓢ DIAGONAL MARKINGS 12 INCH SOLID WHITE LINES (15' O.C. AT 45 DEGREES)
- Ⓣ GORE MARKINGS WITH 12 INCH SOLID WHITE LINES (10' O.C. AT 45 DEGREES)

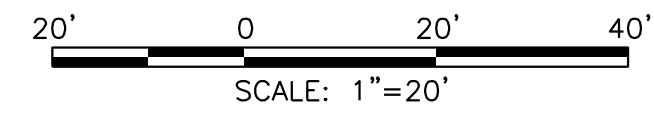

Mead & Hunt
 100 M STREET SE SUITE 550
 WASHINGTON, DC 20003
 (202) 570-7080
 WWW.MEADHUNT.COM

S.I.F. NO. _____
 APPROVED BY _____ DATE _____

PS&E DESIGN
 MARCH 2022
 Not for Construction

DISTRICT OF COLUMBIA DEPARTMENT OF TRANSPORTATION TRAFFIC ENGINEERING AND SAFETY DIVISION		FINAL
PARK PLACE /5TH STREET - PROTECTED BIKE LANE FROM HOBART PLACE NW TO GRANT CIRCLE NW, PARK ROAD WESTBOUND ONE-WAY FROM PARK PLACE NW TO GEORGIA AVENUE NW SIGNING AND PAVEMENT MARKING		FIELD CHECKED BY MP/TK
DESIGNED BY MP DRAWN BY MP		REVIEWED BY RF
RECOMMENDED FOR APPROVAL: TRAFFIC SIGNAL DESIGN ENGINEER _____ TRAFFIC SIGNAL PROGRAM MANAGER _____		DATE 03 /2022
APPROVED: TRAFFIC SIGNAL DIVISION MANAGER /ASSOCIATE DIRECTOR _____		SCALE 1" = 20'
DATE: _____		SHEET 52 OF 80
		DRAWING NO. SN-5

3/22/2022 RA:2019\08_0001 ID:0 Traffic Eng Des JMT\Task 17 - Park Place_PBL\Draw\Signing\SN-005_Park_PL_NW.dgn

REG	STATE	PROJECT	SHEET NO.	TOTAL SHEETS
3	D.C.		53	80

DESCRIPTION	REVISION						
	DATE	COR.	CHK.	APP.	APP.	APP.	APP.

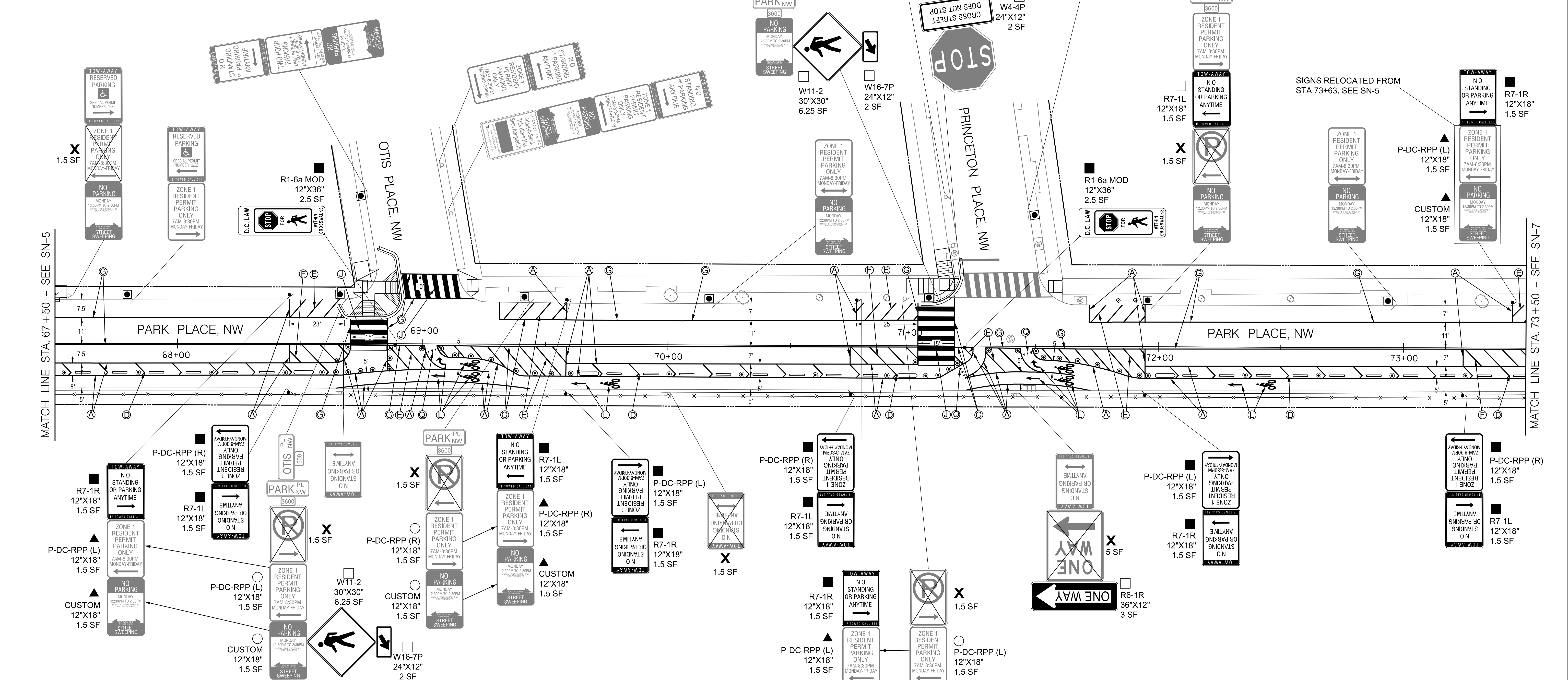

SIGNING LEGEND

ALL EXISTING SIGNS SHALL REMAIN IN PLACE UNLESS OTHERWISE NOTED.

- X EXISTING SIGN TO BE REMOVED
- EXISTING SIGN TO BE RELOCATED
- △ EXISTING SIGN RELOCATED TO EXISTING POST OR EXISTING SIGNAL POLE / LIGHT POLE
- ▲ EXISTING SIGN RELOCATED TO NEW POST
- NEW SIGN TO BE INSTALLED ON EXISTING POST OR EXISTING SIGNAL POLE / LIGHT POLE
- NEW SIGN TO BE INSTALLED ON NEW POST

PAVEMENT MARKING LEGEND

- Ⓐ 4 INCH SOLID WHITE LANE LINE
- Ⓑ 4 INCH DOTTED WHITE LANE LINE (2' STRIPE, 4' SKIP)
- Ⓒ 4 INCH DASHED WHITE LANE LINE (10' STRIPE, 30' SKIP)
- Ⓓ GORE MARKINGS WITH 4 INCH SOLID WHITE LINES (15' O.C. AT 45 DEGREES)
- Ⓔ DIAGONAL MARKINGS 4 INCH SOLID WHITE LINES (5' O.C. AT 45 DEGREES)
- Ⓕ DIAGONAL MARKINGS 4 INCH SOLID WHITE LINES (7.5' O.C. AT 45 DEGREES)
- Ⓖ 6 INCH SOLID WHITE LANE LINE
- Ⓗ 12 INCH WHITE STOP BAR
- Ⓙ 24 INCH WHITE CROSSWALK STRIPE
- Ⓚ 4 INCH DOUBLE SOLID YELLOW LANE LINE
- Ⓛ WHITE BICYCLE LANE SYMBOL OR ARROW
- Ⓜ GREEN COLORED PAVEMENT WITH 4 INCH LANE LINE BORDER
- Ⓝ 24" GREEN BICYCLE CROSSING FOR ONE WAY BIKE LANE (SEE DETAIL ON SHEET SN-DE2)
- Ⓟ DIAGONAL MARKINGS 4 INCH SOLID YELLOW LINES (15' O.C. AT 45 DEGREES)
- Ⓠ YIELD LINE SYMBOL
- Ⓡ WHITE SHARROWS
- Ⓢ DIAGONAL MARKINGS 12 INCH SOLID WHITE LINES (15' O.C. AT 45 DEGREES)
- Ⓣ GORE MARKINGS WITH 12 INCH SOLID WHITE LINES (10' O.C. AT 45 DEGREES)

0' 20' 40'

SCALE: 1" = 20'

Mead & Hunt

100 M STREET SE
SUITE 550
WASHINGTON, DC 20003
(202) 570-7080
WWW.MEADHUNT.COM

S.I.F. NO. _____

APPROVED BY _____ DATE _____

DISTRICT OF COLUMBIA
DEPARTMENT OF TRANSPORTATION
TRAFFIC ENGINEERING AND SAFETY DIVISION

PARK PLACE /5TH STREET – PROTECTED BIKE LANE
FROM HOBART PLACE NW TO GRANT CIRCLE NW,
PARK ROAD WESTBOUND ONE-WAY
FROM PARK PLACE NW TO GEORGIA AVENUE NW
SIGNING AND PAVEMENT MARKING

FINAL
FIELD CHECKED BY
MPT/K

DESIGNED BY
MP

DRAWN BY
MP

REVIEWED BY
RF

DATE
03 /2022

SCALE
1" = 20'

SHEET
53 OF
80

DRAWING NO.
SN-6

PS&E DESIGN
MARCH 2022
Not for Construction

3/22/2022 RA\2019\08_0001 ID0 Traffic Eng_Design\Task 17 - Park Place_PBL\Drawings\Signing\PSN-006_Park Pl NW.dgn

REG	STATE	PROJECT	SHEET NO.	TOTAL SHEETS
3	D.C.		54	80

DESCRIPTION	REVISION						
	DATE	COR.	CHK.	APP.	APP.	APP.	APP.

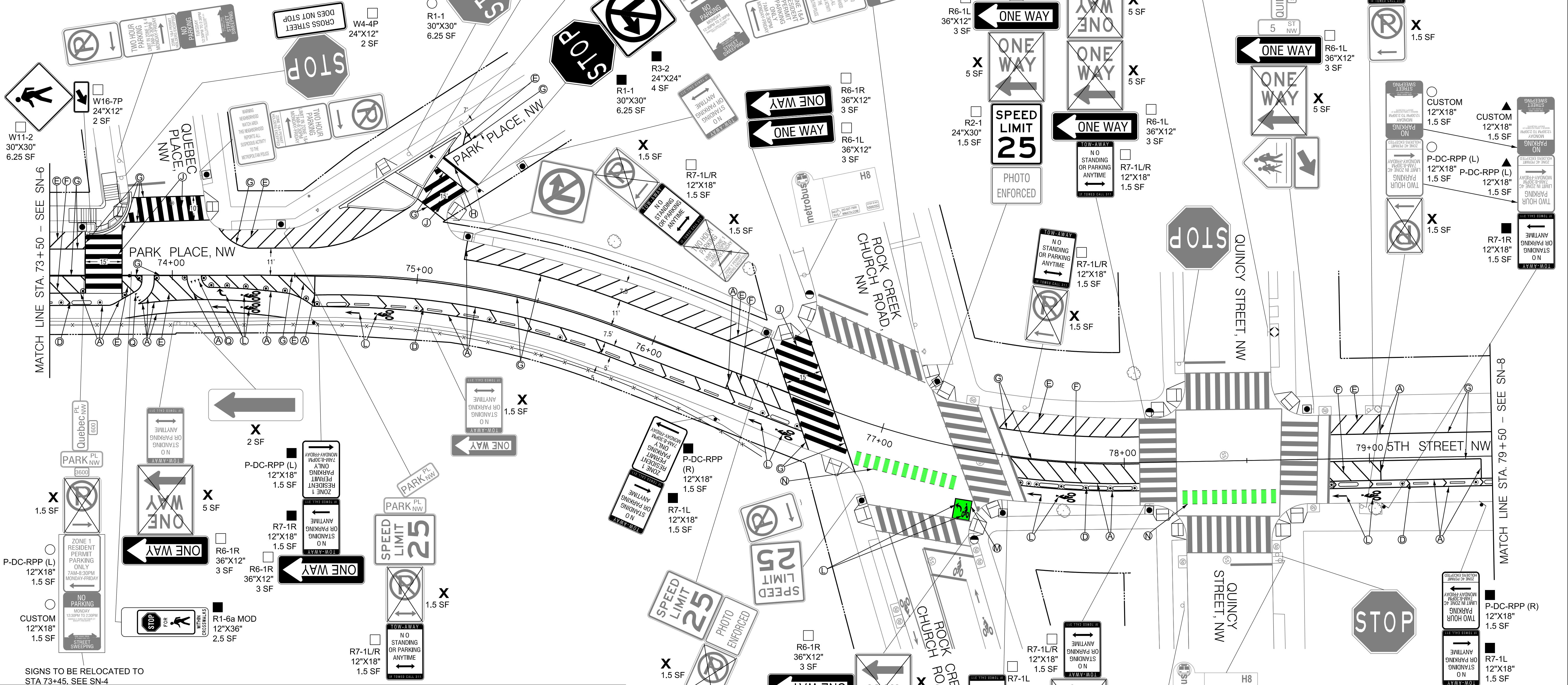

SIGNING LEGEND

ALL EXISTING SIGNS SHALL REMAIN IN PLACE UNLESS OTHERWISE NOTED.

- X EXISTING SIGN TO BE REMOVED
- O EXISTING SIGN TO BE RELOCATED
- △ EXISTING SIGN RELOCATED TO EXISTING POST OR EXISTING SIGNAL POLE / LIGHT POLE
- ▲ EXISTING SIGN RELOCATED TO NEW POST
- NEW SIGN TO BE INSTALLED ON EXISTING POST OR EXISTING SIGNAL POLE / LIGHT POLE
- NEW SIGN TO BE INSTALLED ON NEW POST

PAVEMENT MARKING LEGEND

- Ⓐ 4 INCH SOLID WHITE LANE LINE
- Ⓑ 4 INCH DOTTED WHITE LANE LINE (2' STRIPE, 4' SKIP)
- Ⓒ 4 INCH DASHED WHITE LANE LINE (10' STRIPE, 30' SKIP)
- Ⓓ GORE MARKINGS WITH 4 INCH SOLID WHITE LINES (15' O.C. AT 45 DEGREES)
- Ⓔ DIAGONAL MARKINGS 4 INCH SOLID WHITE LINES (5' O.C. AT 45 DEGREES)
- Ⓕ DIAGONAL MARKINGS 4 INCH SOLID WHITE LINES (7.5' O.C. AT 45 DEGREES)
- Ⓖ 6 INCH SOLID WHITE LANE LINE
- Ⓗ 12 INCH WHITE STOP BAR
- Ⓙ 24 INCH WHITE CROSSWALK STRIPE
- Ⓚ 4 INCH DOUBLE SOLID YELLOW LANE LINE
- Ⓛ WHITE BICYCLE LANE SYMBOL OR ARROW
- Ⓜ GREEN COLORED PAVEMENT WITH 4 INCH LANE LINE BORDER
- Ⓝ 24" GREEN BICYCLE CROSSING FOR ONE WAY BIKE LANE (SEE DETAIL ON SHEET SN-DE2)
- Ⓟ DIAGONAL MARKINGS 4 INCH SOLID YELLOW LINES(15' O.C. AT 45 DEGREES)
- Ⓠ YIELD LINE SYMBOL
- Ⓡ WHITE SHARROWS
- Ⓢ DIAGONAL MARKINGS 12 INCH SOLID WHITE LINES (15' O.C. AT 45 DEGREES)
- Ⓣ GORE MARKINGS WITH 12 INCH SOLID WHITE LINES (10' O.C. AT 45 DEGREES)

SCALE: 1" = 20'

Mead & Hunt

100 M STREET SE
SUITE 550
WASHINGTON, DC 20003
(202) 570-7080
WWW.MEADHUNT.COM

S.I.F. NO. _____
APPROVED BY _____ DATE _____

PS&E DESIGN
MARCH 2022
Not for Construction

DISTRICT OF COLUMBIA DEPARTMENT OF TRANSPORTATION TRAFFIC ENGINEERING AND SAFETY DIVISION		FINAL
PARK PLACE /5TH STREET – PROTECTED BIKE LANE FROM HOBART PLACE NW TO GRANT CIRCLE NW, PARK ROAD WESTBOUND ONE-WAY FROM PARK PLACE NW TO GEORGIA AVENUE NW SIGNING AND PAVEMENT MARKING		FIELD CHECKED BY MP/TK
DESIGNED BY MP	DRAWN BY MP	REVIEWED BY RF
RECOMMENDED FOR APPROVAL:	DATE 03 / 2022	SCALE 1" = 20'
TRAFFIC SIGNAL DESIGN ENGINEER	APPROVED:	SHEET 54 OF 80
TRAFFIC SIGNAL PROGRAM MANAGER	TRAFFIC SIGNAL DIVISION MANAGER /ASSOCIATE DIRECTOR	DRAWING NO. SN-7
DATE: _____		

3/22/2022 RA:2019.08 DD01 ID:0 Traffic Eng_Design_JMT\Task 17 - Park Place_PBL\Drawings\Signing\PSN-007_Park Pl_NW.dgn

REG	STATE	PROJECT	SHEET NO.	TOTAL SHEETS
3	D.C.		55	80

DESCRIPTION	REVISION						
	DATE	COR.	CHK.	APP.	APP.	APP.	APP.

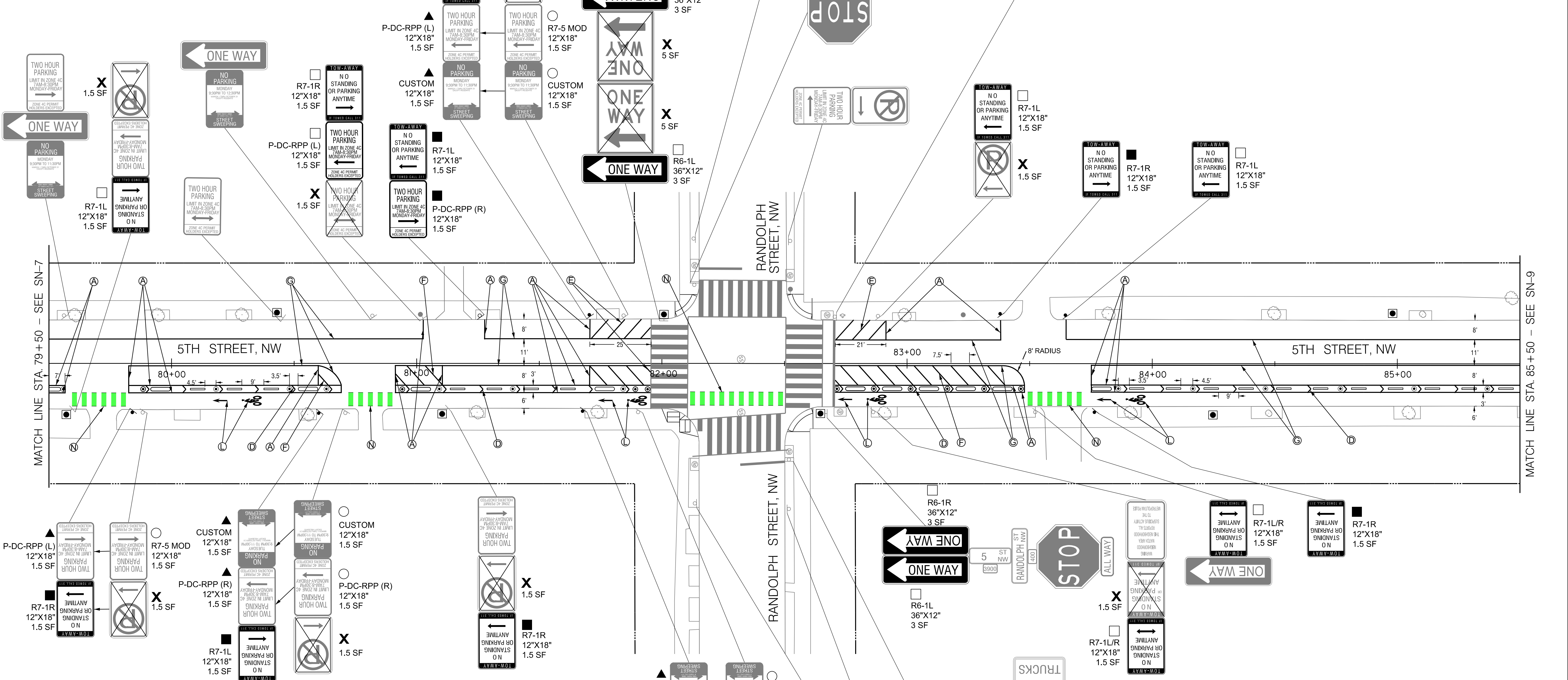

SIGNING LEGEND

ALL EXISTING SIGNS SHALL REMAIN IN PLACE UNLESS OTHERWISE NOTED.

- X EXISTING SIGN TO BE REMOVED
- EXISTING SIGN TO BE RELOCATED
- △ EXISTING SIGN RELOCATED TO EXISTING POST OR EXISTING SIGNAL POLE / LIGHT POLE
- ▲ EXISTING SIGN RELOCATED TO NEW POST
- NEW SIGN TO BE INSTALLED ON EXISTING POST OR EXISTING SIGNAL POLE / LIGHT POLE
- NEW SIGN TO BE INSTALLED ON NEW POST

PAVEMENT MARKING LEGEND

- Ⓐ 4 INCH SOLID WHITE LANE LINE
- Ⓑ 4 INCH DOTTED WHITE LANE LINE (2' STRIPE, 4' SKIP)
- Ⓒ 4 INCH DASHED WHITE LANE LINE (10' STRIPE, 30' SKIP)
- Ⓓ GORE MARKINGS WITH 4 INCH SOLID WHITE LINES (15' O.C. AT 45 DEGREES)
- Ⓔ DIAGONAL MARKINGS 4 INCH SOLID WHITE LINES (5' O.C. AT 45 DEGREES)
- Ⓕ DIAGONAL MARKINGS 4 INCH SOLID WHITE LINES (7.5' O.C. AT 45 DEGREES)
- Ⓖ 6 INCH SOLID WHITE LANE LINE
- Ⓗ 12 INCH WHITE STOP BAR
- Ⓘ 24 INCH WHITE CROSSWALK STRIPE
- Ⓚ 4 INCH DOUBLE SOLID YELLOW LANE LINE
- Ⓛ WHITE BICYCLE LANE SYMBOL OR ARROW
- Ⓜ GREEN COLORED PAVEMENT WITH 4 INCH LANE LINE BORDER
- Ⓝ 24" GREEN BICYCLE CROSSING FOR ONE WAY BIKE LANE (SEE DETAIL ON SHEET SN-DE2)
- Ⓟ DIAGONAL MARKINGS 4 INCH SOLID YELLOW LINES (15' O.C. AT 45 DEGREES)
- Ⓠ YIELD LINE SYMBOL
- Ⓡ WHITE SHARROWS
- Ⓢ DIAGONAL MARKINGS 12 INCH SOLID WHITE LINES (15' O.C. AT 45 DEGREES)
- Ⓣ GORE MARKINGS WITH 12 INCH SOLID WHITE LINES (10' O.C. AT 45 DEGREES)

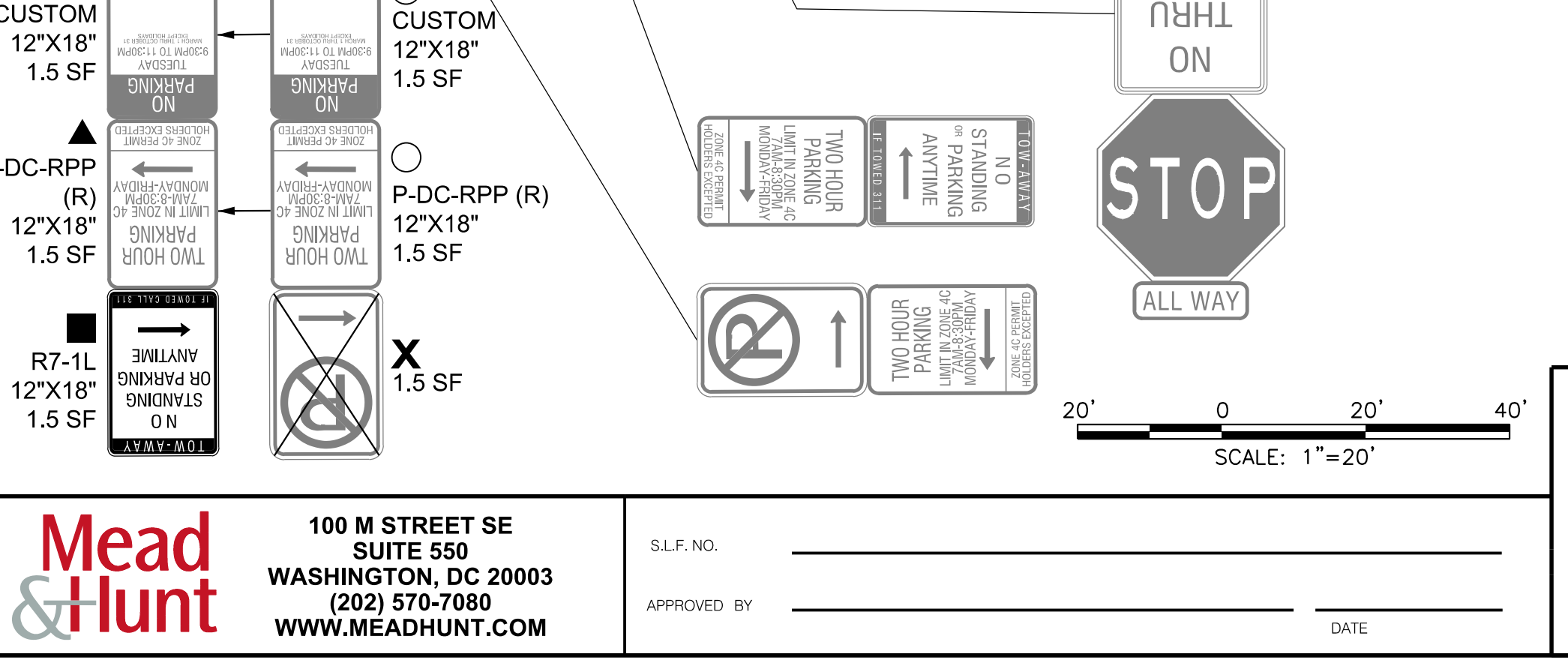

DISTRICT OF COLUMBIA
DEPARTMENT OF TRANSPORTATION
TRAFFIC ENGINEERING AND SAFETY DIVISION

PARK PLACE /5TH STREET – PROTECTED BIKE LANE
FROM HOBART PLACE NW TO GRANT CIRCLE NW,
PARK ROAD WESTBOUND ONE-WAYING
FROM PARK PLACE NW TO GEORGIA AVENUE NW
SIGNING AND PAVEMENT MARKING

RECOMMENDED FOR APPROVAL:

TRAFFIC SIGNAL DESIGN ENGINEER _____

TRAFFIC SIGNAL PROGRAM MANAGER _____

APPROVED: _____

TRAFFIC SIGNAL DIVISION MANAGER / ASSOCIATE DIRECTOR _____

DATE: _____

FINAL

FIELD CHECKED BY: MPTK

DESIGNED BY: MP

DRAWN BY: MP

REVIEWED BY: RF

DATE: 03 /2022

SCALE: 1" = 20'

SHEET 55 OF 80

DRAWING NO. SN-8

PS&E DESIGN
MARCH 2022
Not for Construction

Mead & Hunt
100 M STREET SE
SUITE 550
WASHINGTON, DC 20003
(202) 570-7080
WWW.MEADHUNT.COM

S.I.F. NO. _____

APPROVED BY _____ DATE _____

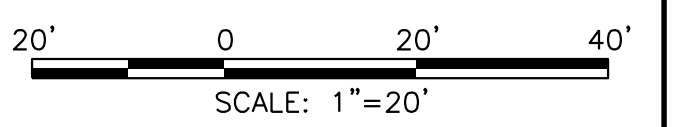

3/22/2022 ID:0 Traffic Eng_Design\Task 17 - Park Place_PBL\Drawings\Signing\PSN-008_Park Pl_NW.dgn

DESCRIPTION	REVISION						
	DATE	COR.	CHK.	APP.	APP.	APP.	APP.

REG	STATE	PROJECT	SHEET NO.	TOTAL SHEETS
3	D.C.		56	80

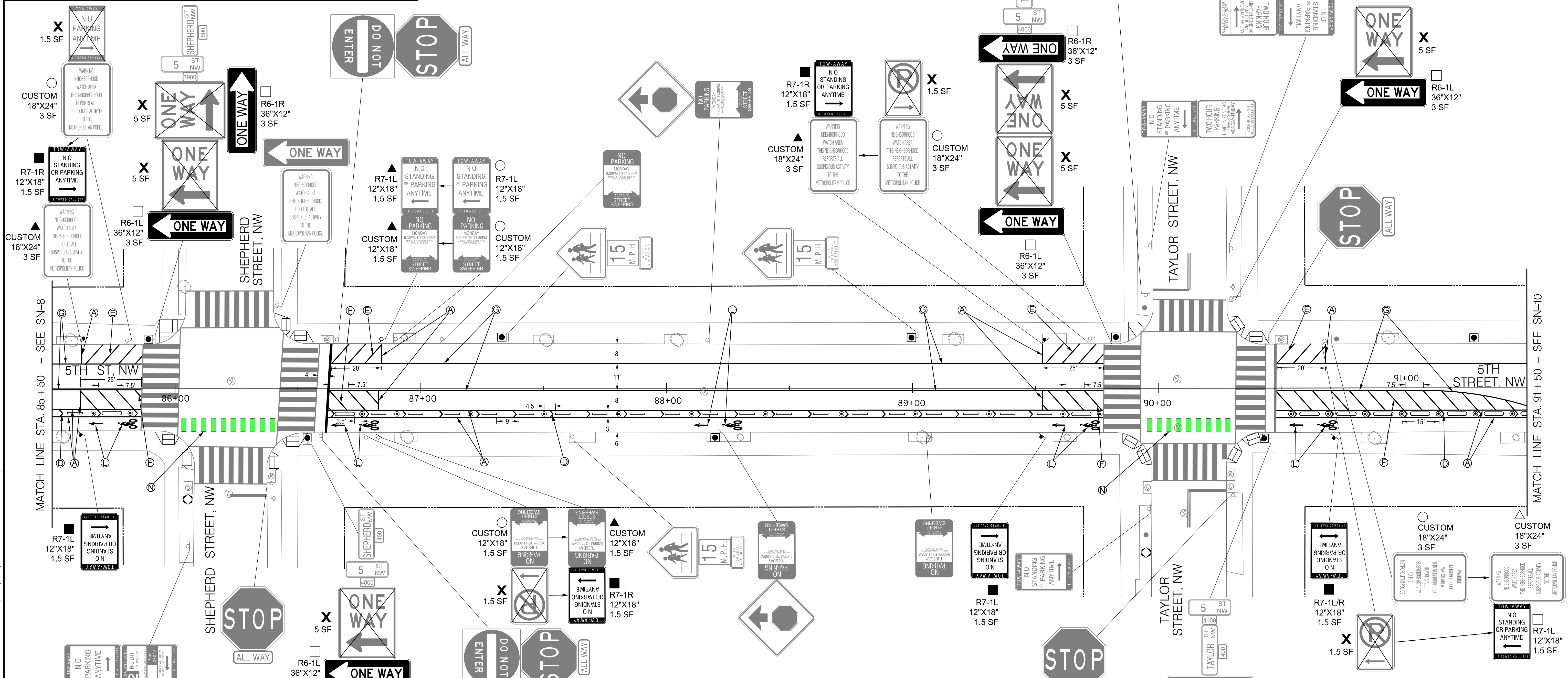
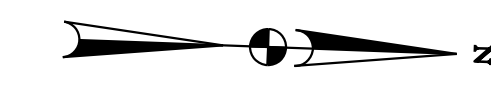

SIGNING LEGEND

ALL EXISTING SIGNS SHALL REMAIN IN PLACE UNLESS OTHERWISE NOTED.

- X EXISTING SIGN TO BE REMOVED
- O EXISTING SIGN TO BE RELOCATED
- △ EXISTING SIGN RELOCATED TO EXISTING POST OR EXISTING SIGNAL POLE / LIGHT POLE
- ▲ EXISTING SIGN RELOCATED TO NEW POST
- NEW SIGN TO BE INSTALLED ON EXISTING POST OR EXISTING SIGNAL POLE / LIGHT POLE
- NEW SIGN TO BE INSTALLED ON NEW POST

PAVEMENT MARKING LEGEND

- Ⓐ 4 INCH SOLID WHITE LANE LINE
- Ⓑ 4 INCH DOTTED WHITE LANE LINE (2' STRIPE, 4' SKIP)
- Ⓒ 4 INCH DASHED WHITE LANE LINE (10' STRIPE, 30' SKIP)
- Ⓓ GORE MARKINGS WITH 4 INCH SOLID WHITE LINES (15' O.C. AT 45 DEGREES)
- Ⓔ DIAGONAL MARKINGS 4 INCH SOLID WHITE LINES (5' O.C. AT 45 DEGREES)
- Ⓕ DIAGONAL MARKINGS 4 INCH SOLID WHITE LINES (7.5' O.C. AT 45 DEGREES)
- Ⓖ 6 INCH SOLID WHITE LANE LINE
- Ⓗ 12 INCH WHITE STOP BAR
- Ⓙ 24 INCH WHITE CROSSWALK STRIPE
- Ⓚ 4 INCH DOUBLE SOLID YELLOW LANE LINE
- Ⓛ WHITE BICYCLE LANE SYMBOL OR ARROW
- Ⓜ GREEN COLORED PAVEMENT WITH 4 INCH LANE LINE BORDER
- Ⓝ 24" GREEN BICYCLE CROSSING FOR ONE WAY BIKE LANE (SEE DETAIL ON SHEET SN-DE2)
- Ⓞ DIAGONAL MARKINGS 4 INCH SOLID YELLOW LINES(15' O.C. AT 45 DEGREES)
- Ⓟ YIELD LINE SYMBOL
- Ⓠ WHITE SHARROWS
- Ⓡ DIAGONAL MARKINGS 12 INCH SOLID WHITE LINES (15' O.C. AT 45 DEGREES)
- Ⓢ GORE MARKINGS WITH 12 INCH SOLID WHITE LINES (10' O.C. AT 45 DEGREES)

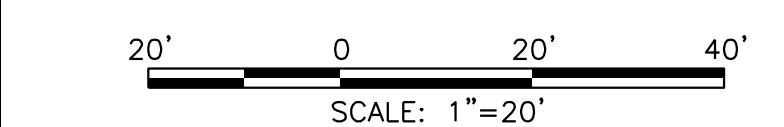

Mead & Hunt
 100 M STREET SE SUITE 550
 WASHINGTON, DC 20003
 (202) 570-7080
 WWW.MEADHUNT.COM

S.I.F. NO. _____
 APPROVED BY _____ DATE _____

DISTRICT OF COLUMBIA
 DEPARTMENT OF TRANSPORTATION
 TRAFFIC ENGINEERING AND SAFETY DIVISION

PARK PLACE /5TH STREET – PROTECTED BIKE LANE FROM HOBART PLACE NW TO GRANT CIRCLE NW, PARK ROAD WESTBOUND ONE-WAYING FROM PARK PLACE NW TO GEORGIA AVENUE NW SIGNING AND PAVEMENT MARKING

<p>RECOMMENDED FOR APPROVAL:</p> <p>TRAFFIC SIGNAL DESIGN ENGINEER _____</p> <p>TRAFFIC SIGNAL PROGRAM MANAGER _____</p> <p>APPROVED: _____</p> <p>TRAFFIC SIGNAL DIVISION MANAGER /ASSOCIATE DIRECTOR _____</p> <p>DATE: _____</p>	<p>FINAL</p> <p>FIELD CHECKED BY: MPTK</p> <p>DESIGNED BY: MP</p> <p>DRAWN BY: MP</p> <p>REVIEWED BY: RF</p> <p>DATE: 03 /2022</p> <p>SCALE: 1" = 20'</p> <p>SHEET 56 OF 80</p> <p>DRAWING NO. SN-9</p>
---	---

PS&E DESIGN
 MARCH 2022
 Not for Construction

3/22/2022 RA:2019\08_0001 ID:0 Traffic Eng Des JMT\Task 17 - Park Place_PBL\Draw\Signing\PSN-009_Park Pl NW.dgn

REG	STATE	PROJECT	SHEET NO.	TOTAL SHEETS
3	D.C.		57	80

DESCRIPTION	REVISION						
	DATE	COR.	CHK.	APP.	APP.	APP.	APP.

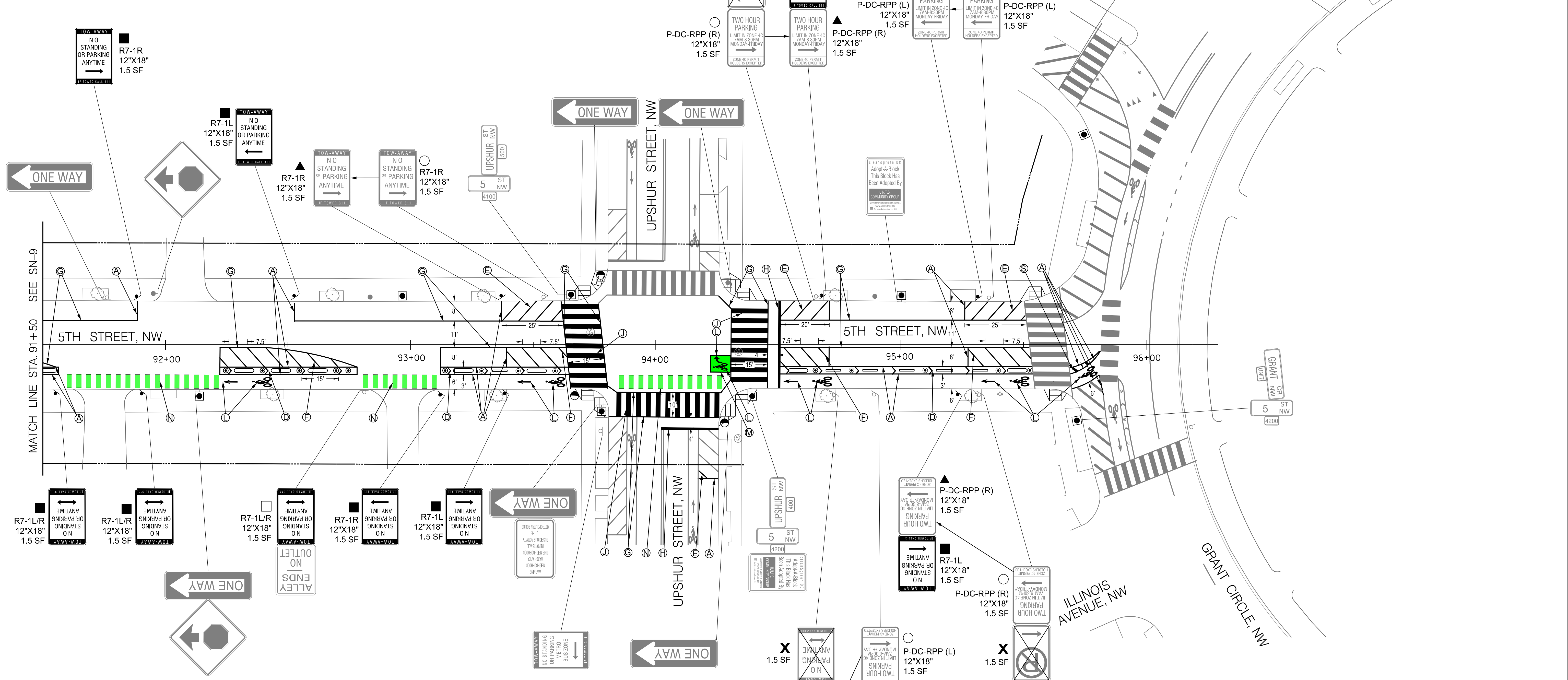

SIGNING LEGEND		PAVEMENT MARKING LEGEND	
ALL EXISTING SIGNS SHALL REMAIN IN PLACE UNLESS OTHERWISE NOTED.		(A) 4 INCH SOLID WHITE LANE LINE	
X EXISTING SIGN TO BE REMOVED		(B) 4 INCH DOTTED WHITE LANE LINE (2' STRIPE, 4' SKIP)	
O EXISTING SIGN TO BE RELOCATED		(C) 4 INCH DASHED WHITE LANE LINE (10' STRIPE, 30' SKIP)	
△ EXISTING SIGN RELOCATED TO EXISTING POST OR EXISTING SIGNAL POLE / LIGHT POLE		(D) GORE MARKINGS WITH 4 INCH SOLID WHITE LINES (15' O.C. AT 45 DEGREES)	
▲ EXISTING SIGN RELOCATED TO NEW POST		(E) DIAGONAL MARKINGS 4 INCH SOLID WHITE LINES (5' O.C. AT 45 DEGREES)	
□ NEW SIGN TO BE INSTALLED ON EXISTING POST OR EXISTING SIGNAL POLE / LIGHT POLE		(F) DIAGONAL MARKINGS 4 INCH SOLID WHITE LINES (7.5' O.C. AT 45 DEGREES)	
■ NEW SIGN TO BE INSTALLED ON NEW POST		(G) 6 INCH SOLID WHITE LANE LINE	
		(H) 12 INCH WHITE STOP BAR	
		(J) 24 INCH WHITE CROSSWALK STRIPE	
		(K) 4 INCH DOUBLE SOLID YELLOW LANE LINE	
		(L) WHITE BICYCLE LANE SYMBOL OR ARROW	
		(M) GREEN COLORED PAVEMENT WITH 4 INCH LANE LINE BORDER	
		(N) 24" GREEN BICYCLE CROSSING FOR ONE WAY BIKE LANE (SEE DETAIL ON SHEET SN-DE2)	
		(P) DIAGONAL MARKINGS 4 INCH SOLID YELLOW LINES (15' O.C. AT 45 DEGREES)	
		(Q) YIELD LINE SYMBOL	
		(R) WHITE SHARROWS	
		(S) DIAGONAL MARKINGS 12 INCH SOLID WHITE LINES (15' O.C. AT 45 DEGREES)	
		(T) GORE MARKINGS WITH 12 INCH SOLID WHITE LINES (10' O.C. AT 45 DEGREES)	

SCALE: 1" = 20'

Mead & Hunt
 100 M STREET SE SUITE 550
 WASHINGTON, DC 20003
 (202) 570-7080
 WWW.MEADHUNT.COM

S.I.F. NO. _____
 APPROVED BY _____ DATE _____

DISTRICT OF COLUMBIA
 DEPARTMENT OF TRANSPORTATION
 TRAFFIC ENGINEERING AND SAFETY DIVISION

PARK PLACE /5TH STREET – PROTECTED BIKE LANE
 FROM HOBART PLACE NW TO GRANT CIRCLE NW,
 PARK ROAD WESTBOUND ONE-WAYING
 FROM PARK PLACE NW TO GEORGIA AVENUE NW
 SIGNING AND PAVEMENT MARKING

RECOMMENDED FOR APPROVAL:
 TRAFFIC SIGNAL DESIGN ENGINEER _____
 TRAFFIC SIGNAL PROGRAM MANAGER _____
 APPROVED: _____
 TRAFFIC SIGNAL DIVISION MANAGER / ASSOCIATE DIRECTOR _____
 DATE: _____

FINAL
 FIELD CHECKED BY: MP/TK
 DESIGNED BY: MP
 DRAWN BY: MP
 REVIEWED BY: RF
 DATE: 03 /2022
 SCALE: 1" = 20'
 SHEET 57 OF 80
 DRAWING NO. SN-10

PS&E DESIGN
 MARCH 2022
 Not for Construction

3/22/2022 RA\2019\08_0001 ID0 Traffic Eng Des JMT\Task 17 - Park Place_PBL\Draw\Signing\pSN-010_Park PI NW.dgn

REG.	STATE	PROJECT	SHEET NO.	TOTAL SHEETS
3	D.C.		58	80

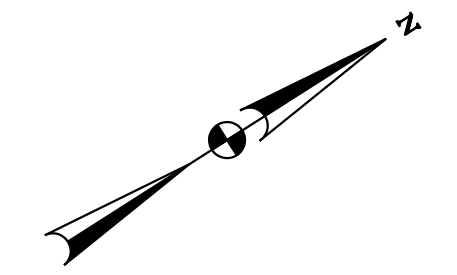

DESCRIPTION	REVISION							
	DATE	COR.	CHK.	APP.	APP.	APP.	APP.	APP.

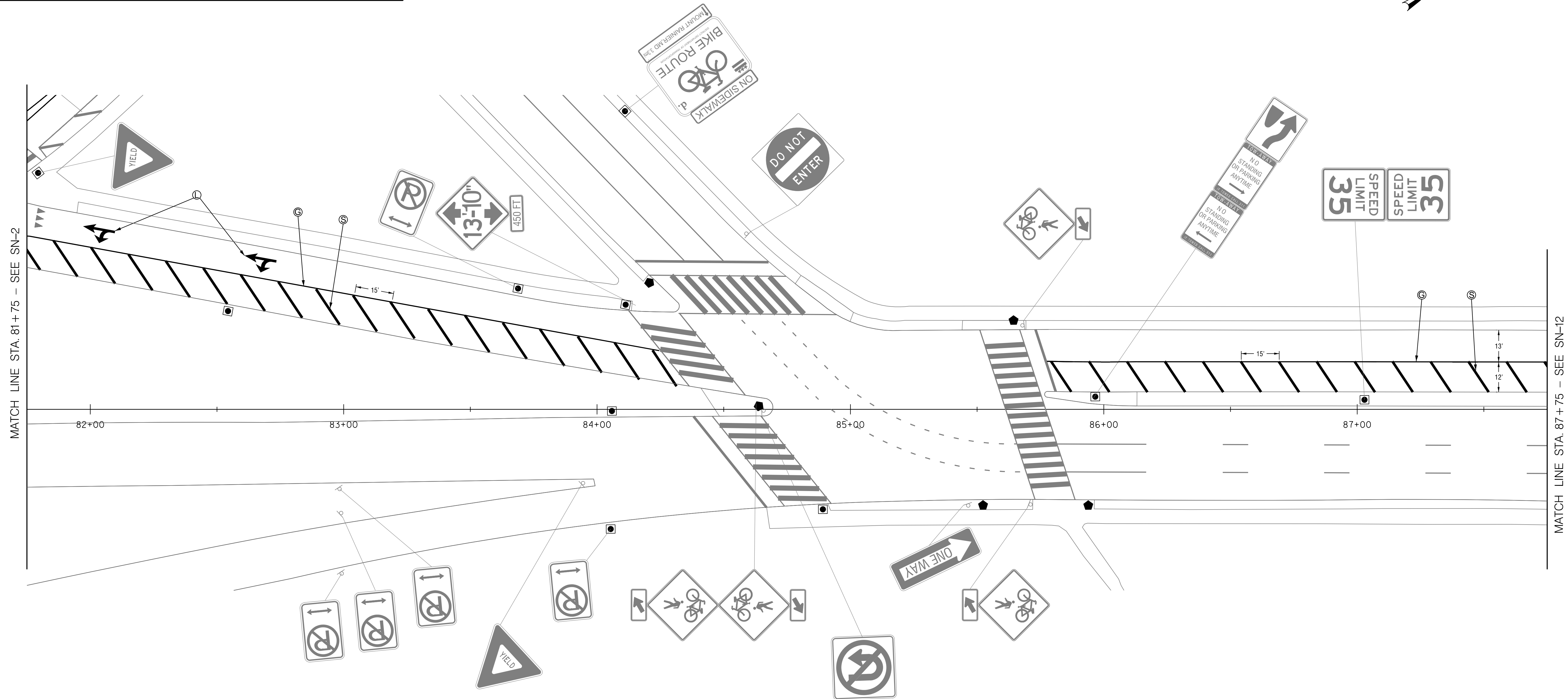

SIGNING LEGEND		PAVEMENT MARKING LEGEND	
✕	EXISTING SIGN TO BE REMOVED	Ⓐ	4 INCH SOLID WHITE LANE LINE
○	EXISTING SIGN TO BE RELOCATED	Ⓑ	4 INCH DOTTED WHITE LANE LINE (2' STRIPE, 4' SKIP)
△	EXISTING SIGN RELOCATED TO EXISTING POST OR EXISTING SIGNAL POLE / LIGHT POLE	Ⓒ	4 INCH DASHED WHITE LANE LINE (10' STRIPE, 30' SKIP)
▲	EXISTING SIGN RELOCATED TO NEW POST	Ⓓ	GORE MARKINGS WITH 4 INCH SOLID WHITE LINES (15' O.C. AT 45 DEGREES)
□	NEW SIGN TO BE INSTALLED ON EXISTING POST OR EXISTING SIGNAL POLE / LIGHT POLE	Ⓔ	DIAGONAL MARKINGS 4 INCH SOLID WHITE LINES (5' O.C. AT 45 DEGREES)
■	NEW SIGN TO BE INSTALLED ON NEW POST	Ⓕ	DIAGONAL MARKINGS 4 INCH SOLID WHITE LINES (7.5' O.C. AT 45 DEGREES)
		Ⓖ	6 INCH SOLID WHITE LANE LINE
		Ⓗ	12 INCH WHITE STOP BAR
		Ⓙ	24 INCH WHITE CROSSWALK STRIPE
		Ⓚ	4 INCH DOUBLE SOLID YELLOW LANE LINE
		Ⓛ	WHITE BICYCLE LANE SYMBOL OR ARROW
		Ⓜ	GREEN COLORED PAVEMENT WITH 4 INCH LANE LINE BORDER
		Ⓝ	24" GREEN BICYCLE CROSSING FOR ONE WAY BIKE LANE (SEE DETAIL ON SHEET SN-DE2)
		Ⓟ	DIAGONAL MARKINGS 4 INCH SOLID YELLOW LINES(15' O.C. AT 45 DEGREES)
		Ⓠ	YIELD LINE SYMBOL
		Ⓡ	WHITE SHARROWS
		Ⓢ	DIAGONAL MARKINGS 12 INCH SOLID WHITE LINES (15' O.C. AT 45 DEGREES)
		Ⓣ	GORE MARKINGS WITH 12 INCH SOLID WHITE LINES (10' O.C. AT 45 DEGREES)

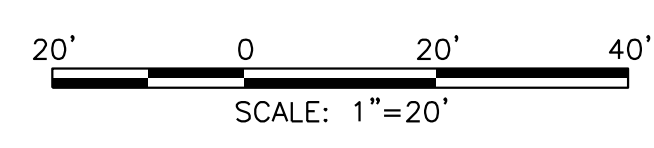

Mead & Hunt
 100 M STREET SE
 SUITE 550
 WASHINGTON, DC 20003
 (202) 570-7080
 WWW.MEADHUNT.COM

S.I.F. NO. _____
 APPROVED BY _____ DATE _____

PS&E DESIGN
 MARCH 2022
 Not for Construction

DISTRICT OF COLUMBIA DEPARTMENT OF TRANSPORTATION TRAFFIC ENGINEERING AND SAFETY DIVISION		FINAL
PARK PLACE /5TH STREET - PROTECTED BIKE LANE FROM HOBART PLACE NW TO GRANT CIRCLE NW, PARK ROAD WESTBOUND ONE-WAYING FROM PARK PLACE NW TO GEORGIA AVENUE NW SIGNING AND PAVEMENT MARKING		FIELD CHECKED BY MP/TK
DESIGNED BY MP	DRAWN BY MP	REVIEWED BY RF
RECOMMENDED FOR APPROVAL:	DATE 03 /2022	SCALE 1" = 20'
TRAFFIC SIGNAL DESIGN ENGINEER _____	TRAFFIC SIGNAL PROGRAM MANAGER _____	SHEET 58 OF 80
APPROVED:	TRAFFIC SIGNAL DIVISION MANAGER /ASSOCIATE DIRECTOR _____	DRAWING NO. SN-11
DATE: _____		

3/22/2022 RA\2019\08_0001 ID10 Traffic Eng Des JMT\Task 17 - Park Place_PBL\Draw\Signing\psn-01_Park Pl NW.dgn

REG	STATE	PROJECT	SHEET NO.	TOTAL SHEETS
3	D.C.		59	80

DESCRIPTION	REVISION						
	DATE	COR.	CHK.	APP.	APP.	APP.	APP.

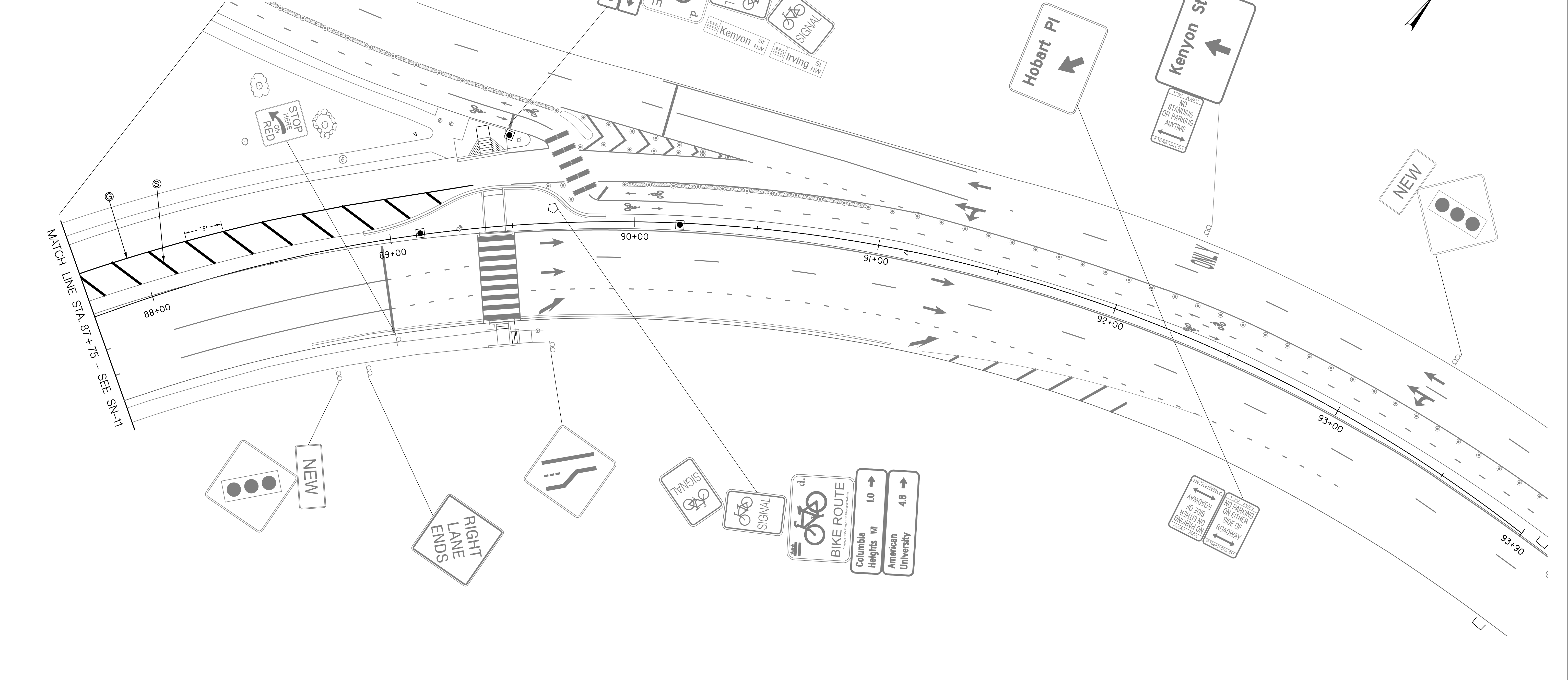

SIGNING LEGEND		PAVEMENT MARKING LEGEND	
ALL EXISTING SIGNS SHALL REMAIN IN PLACE UNLESS OTHERWISE NOTED.		(A) 4 INCH SOLID WHITE LANE LINE	
✕ EXISTING SIGN TO BE REMOVED		(B) 4 INCH DOTTED WHITE LANE LINE (2' STRIPE, 4' SKIP)	
○ EXISTING SIGN TO BE RELOCATED		(C) 4 INCH DASHED WHITE LANE LINE (10' STRIPE, 30' SKIP)	
△ EXISTING SIGN RELOCATED TO EXISTING POST OR EXISTING SIGNAL POLE / LIGHT POLE		(D) GORE MARKINGS WITH 4 INCH SOLID WHITE LINES (15' O.C. AT 45 DEGREES)	
▲ EXISTING SIGN RELOCATED TO NEW POST		(E) DIAGONAL MARKINGS 4 INCH SOLID WHITE LINES (5' O.C. AT 45 DEGREES)	
□ NEW SIGN TO BE INSTALLED ON EXISTING POST OR EXISTING SIGNAL POLE / LIGHT POLE		(F) DIAGONAL MARKINGS 4 INCH SOLID WHITE LINES (7.5' O.C. AT 45 DEGREES)	
■ NEW SIGN TO BE INSTALLED ON NEW POST		(G) 6 INCH SOLID WHITE LANE LINE	
		(H) 12 INCH WHITE STOP BAR	
		(J) 24 INCH WHITE CROSSWALK STRIPE	
		(K) 4 INCH DOUBLE SOLID YELLOW LANE LINE	
		(L) WHITE BICYCLE LANE SYMBOL OR ARROW	
		(M) GREEN COLORED PAVEMENT WITH 4 INCH LANE LINE BORDER	
		(N) 24" GREEN BICYCLE CROSSING FOR ONE WAY BIKE LANE (SEE DETAIL ON SHEET SN-DE2)	
		(P) DIAGONAL MARKINGS 4 INCH SOLID YELLOW LINES(15' O.C. AT 45 DEGREES)	
		(Q) YIELD LINE SYMBOL	
		(R) WHITE SHARROWS	
		(S) DIAGONAL MARKINGS 12 INCH SOLID WHITE LINES (15' O.C. AT 45 DEGREES)	
		(T) GORE MARKINGS WITH 12 INCH SOLID WHITE LINES (10' O.C. AT 45 DEGREES)	

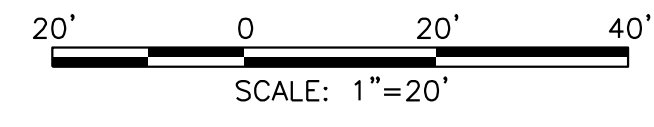

Mead & Hunt
 100 M STREET SE
 SUITE 550
 WASHINGTON, DC 20003
 (202) 570-7080
 WWW.MEADHUNT.COM

S.I.F. NO. _____
 APPROVED BY _____ DATE _____

PS&E DESIGN
 MARCH 2022
 Not for Construction

DISTRICT OF COLUMBIA DEPARTMENT OF TRANSPORTATION TRAFFIC ENGINEERING AND SAFETY DIVISION		FINAL
PARK PLACE /5TH STREET – PROTECTED BIKE LANE FROM HOBART PLACE NW TO GRANT CIRCLE NW, PARK ROAD WESTBOUND ONE-WAYING FROM PARK PLACE NW TO GEORGIA AVENUE NW SIGNING AND PAVEMENT MARKING		FIELD CHECKED BY MP/TK
DESIGNED BY MP	DRAWN BY MP	REVIEWED BY RF
RECOMMENDED FOR APPROVAL: TRAFFIC SIGNAL DESIGN ENGINEER _____ TRAFFIC SIGNAL PROGRAM MANAGER _____	DATE 03 /2022	SCALE 1" = 20'
APPROVED: TRAFFIC SIGNAL DIVISION MANAGER /ASSOCIATE DIRECTOR _____	SHEET 59	OF 80
DATE: _____	DRAWING NO. SN-12	

3/22/2022 RA\2019\08_00\01 ID10 Traffic Eng Des JMT\Task 17 - Park Place_PBL\Dwg\Signing\pSN-012_Park Pl NW.dgn

REG	STATE	PROJECT	SHEET NO.	TOTAL SHEETS
3	D.C.		60	80

DESCRIPTION	REVISION						
	DATE	COR.	CHK.	APP.	APP.	APP.	APP.

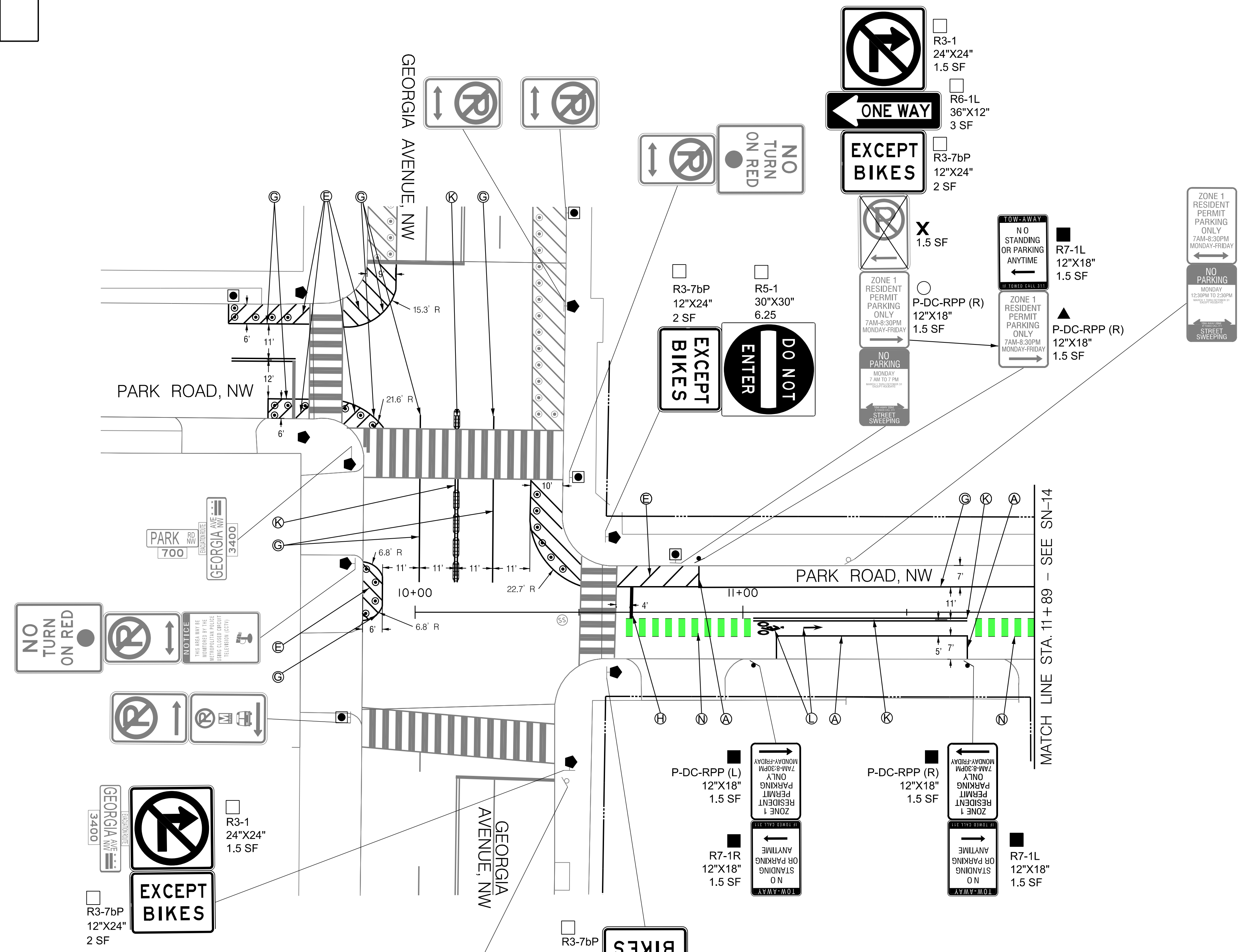

- SIGNING LEGEND**
- ALL EXISTING SIGNS SHALL REMAIN IN PLACE UNLESS OTHERWISE NOTED.
- X EXISTING SIGN TO BE REMOVED
 - EXISTING SIGN TO BE RELOCATED
 - △ EXISTING SIGN RELOCATED TO EXISTING POST OR EXISTING SIGNAL POLE / LIGHT POLE
 - ▲ EXISTING SIGN RELOCATED TO NEW POST
 - NEW SIGN TO BE INSTALLED ON EXISTING POST OR EXISTING SIGNAL POLE / LIGHT POLE
 - NEW SIGN TO BE INSTALLED ON NEW POST

- PAVEMENT MARKING LEGEND**
- Ⓐ 4 INCH SOLID WHITE LANE LINE
 - Ⓑ 4 INCH DOTTED WHITE LANE LINE (2' STRIPE, 4' SKIP)
 - Ⓒ 4 INCH DASHED WHITE LANE LINE (10' STRIPE, 30' SKIP)
 - Ⓓ GORE MARKINGS WITH 4 INCH SOLID WHITE LINES (15' O.C. AT 45 DEGREES)
 - Ⓔ DIAGONAL MARKINGS 4 INCH SOLID WHITE LINES (5' O.C. AT 45 DEGREES)
 - Ⓕ DIAGONAL MARKINGS 4 INCH SOLID WHITE LINES (7.5' O.C. AT 45 DEGREES)
 - Ⓖ 6 INCH SOLID WHITE LANE LINE
 - Ⓗ 12 INCH WHITE STOP BAR
 - Ⓙ 24 INCH WHITE CROSSWALK STRIPE
 - Ⓚ 4 INCH DOUBLE SOLID YELLOW LANE LINE
 - Ⓛ WHITE BICYCLE LANE SYMBOL OR ARROW
 - Ⓜ GREEN COLORED PAVEMENT WITH 4 INCH LANE LINE BORDER
 - Ⓝ 24" GREEN BICYCLE CROSSING FOR ONE WAY BIKE LANE (SEE DETAIL ON SHEET SN-DE2)
 - Ⓟ DIAGONAL MARKINGS 4 INCH SOLID YELLOW LINES(15' O.C. AT 45 DEGREES)
 - Ⓠ YIELD LINE SYMBOL
 - Ⓡ WHITE SHARROWS
 - Ⓢ DIAGONAL MARKINGS 12 INCH SOLID WHITE LINES (15' O.C. AT 45 DEGREES)
 - Ⓣ GORE MARKINGS WITH 12 INCH SOLID WHITE LINES (10' O.C. AT 45 DEGREES)

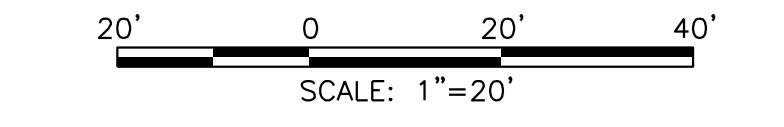
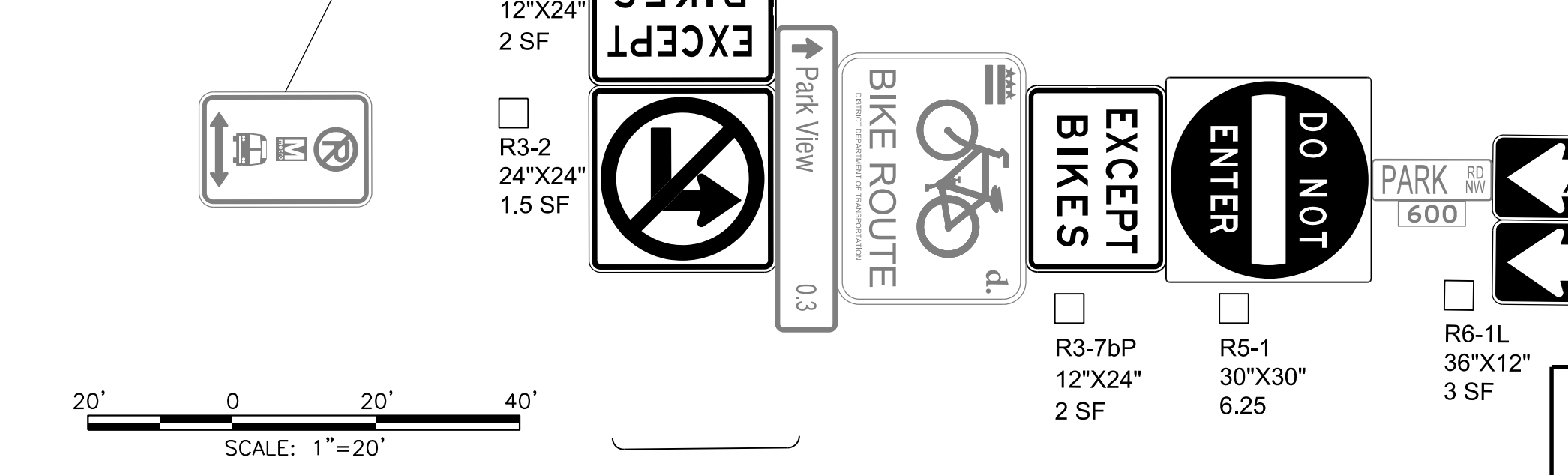

Mead & Hunt
 100 M STREET SE
 SUITE 550
 WASHINGTON, DC 20003
 (202) 570-7080
 WWW.MEADHUNT.COM

S.I.F. NO. _____
 APPROVED BY _____ DATE _____

PS&E DESIGN
 MARCH 2022
 Not for Construction

DISTRICT OF COLUMBIA DEPARTMENT OF TRANSPORTATION TRAFFIC ENGINEERING AND SAFETY DIVISION		FINAL
PARK PLACE /5TH STREET – PROTECTED BIKE LANE FROM HOBART PLACE NW TO GRANT CIRCLE NW, PARK ROAD WESTBOUND ONE-WAYING FROM PARK PLACE NW TO GEORGIA AVENUE NW SIGNING AND PAVEMENT MARKING		FIELD CHECKED BY MP/TK
RECOMMENDED FOR APPROVAL: TRAFFIC SIGNAL DESIGN ENGINEER _____ TRAFFIC SIGNAL PROGRAM MANAGER _____ APPROVED: _____ TRAFFIC SIGNAL DIVISION MANAGER /ASSOCIATE DIRECTOR _____ DATE: _____		DESIGNED BY MP DRAWN BY MP REVIEWED BY RF DATE 03 /2022 SCALE 1" = 20' SHEET 60 OF 80 DRAWING NO. SN-13

3/22/2022 RA:\2019\08_0001\010_Traffic_Eng_Des_JMT\Task_17 - Park_Place_PBL\Draw_Signing\pSN-013_Park_PI_NW.dgn

REG.	STATE	PROJECT	SHEET NO.	TOTAL SHEETS
3	D.C.		61	80

DESCRIPTION	REVISION						
	DATE	COR.	CHK.	APP.	APP.	APP.	APP.

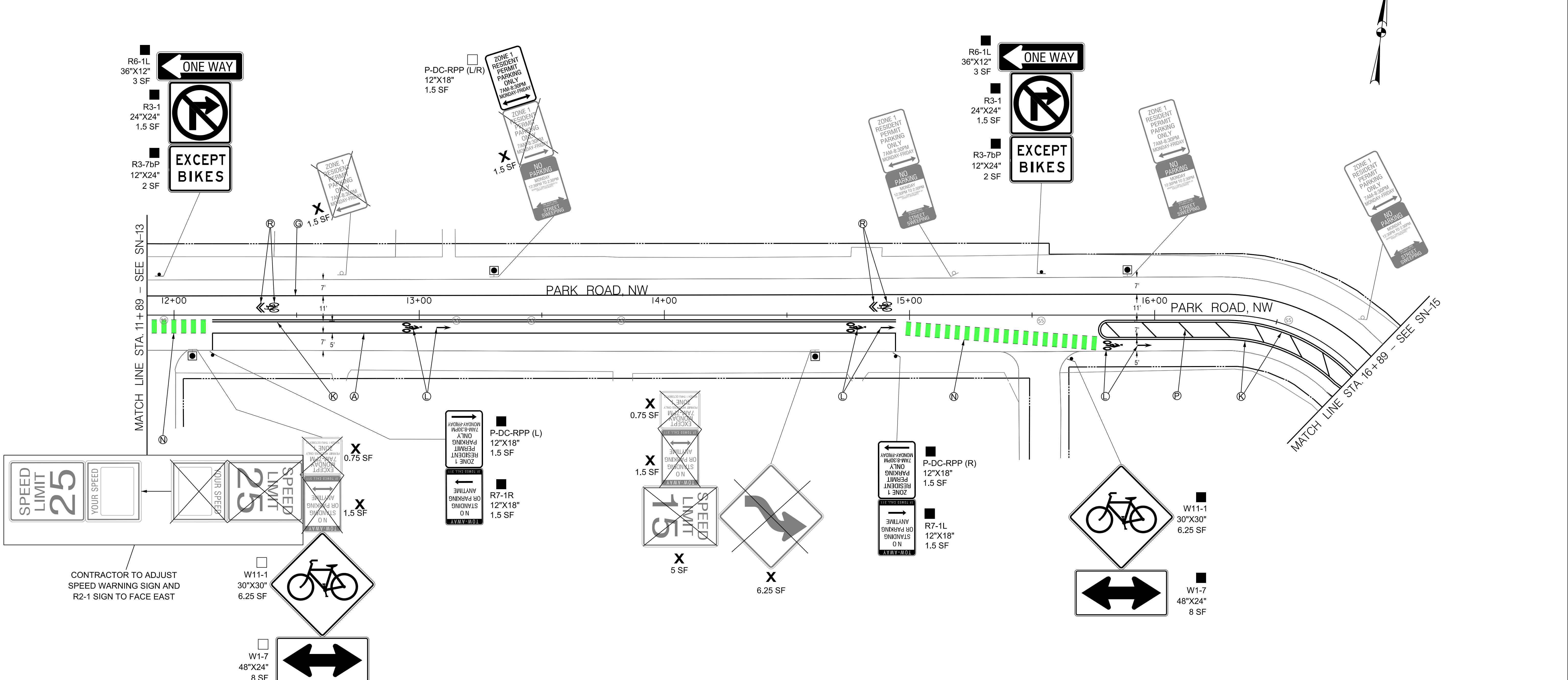

SIGNING LEGEND

ALL EXISTING SIGNS SHALL REMAIN IN PLACE UNLESS OTHERWISE NOTED.

- ✕ EXISTING SIGN TO BE REMOVED
- EXISTING SIGN TO BE RELOCATED
- △ EXISTING SIGN RELOCATED TO EXISTING POST OR EXISTING SIGNAL POLE / LIGHT POLE
- ▲ EXISTING SIGN RELOCATED TO NEW POST
- NEW SIGN TO BE INSTALLED ON EXISTING POST OR EXISTING SIGNAL POLE / LIGHT POLE
- NEW SIGN TO BE INSTALLED ON NEW POST

PAVEMENT MARKING LEGEND

- Ⓐ 4 INCH SOLID WHITE LANE LINE
- Ⓑ 4 INCH DOTTED WHITE LANE LINE (2' STRIPE, 4' SKIP)
- Ⓒ 4 INCH DASHED WHITE LANE LINE (10' STRIPE, 30' SKIP)
- Ⓓ GORE MARKINGS WITH 4 INCH SOLID WHITE LINES (15' O.C. AT 45 DEGREES)
- Ⓔ DIAGONAL MARKINGS 4 INCH SOLID WHITE LINES (5' O.C. AT 45 DEGREES)
- Ⓕ DIAGONAL MARKINGS 4 INCH SOLID WHITE LINES (7.5' O.C. AT 45 DEGREES)
- Ⓖ 6 INCH SOLID WHITE LANE LINE
- Ⓗ 12 INCH WHITE STOP BAR
- Ⓙ 24 INCH WHITE CROSSWALK STRIPE
- Ⓚ 4 INCH DOUBLE SOLID YELLOW LANE LINE
- Ⓛ WHITE BICYCLE LANE SYMBOL OR ARROW
- Ⓜ GREEN COLORED PAVEMENT WITH 4 INCH LANE LINE BORDER
- Ⓝ 24" GREEN BICYCLE CROSSING FOR ONE WAY BIKE LANE (SEE DETAIL ON SHEET SN-DE2)
- Ⓟ DIAGONAL MARKINGS 4 INCH SOLID YELLOW LINES(15 O.C. AT 45 DEGREES)
- Ⓠ YIELD LINE SYMBOL
- Ⓡ WHITE SHARROWS
- Ⓢ DIAGONAL MARKINGS 12 INCH SOLID WHITE LINES (15' O.C. AT 45 DEGREES)
- Ⓣ GORE MARKINGS WITH 12 INCH SOLID WHITE LINES (10' O.C. AT 45 DEGREES)

0 20' 40'

SCALE: 1"=20'

Mead & Hunt

100 M STREET SE
SUITE 550
WASHINGTON, DC 20003
(202) 570-7080
WWW.MEADHUNT.COM

S.I.F. NO. _____

APPROVED BY _____ DATE _____

DISTRICT OF COLUMBIA
DEPARTMENT OF TRANSPORTATION
TRAFFIC ENGINEERING AND SAFETY DIVISION

PARK PLACE /5TH STREET – PROTECTED BIKE LANE
FROM HOBART PLACE NW TO GRANT CIRCLE NW,
PARK ROAD WESTBOUND ONE-WAYING
FROM PARK PLACE NW TO GEORGIA AVENUE NW
SIGNING AND PAVEMENT MARKING

RECOMMENDED FOR APPROVAL:

TRAFFIC SIGNAL DESIGN ENGINEER _____

TRAFFIC SIGNAL PROGRAM MANAGER _____

APPROVED: _____

TRAFFIC SIGNAL DIVISION MANAGER /ASSOCIATE DIRECTOR _____

DATE: _____

FINAL
FIELD CHECKED BY
MP/TK

DESIGNED BY
MP

DRAWN BY
MP

REVIEWED BY
RF

DATE
03 /2022

SCALE
1" = 20'

SHEET 61 OF 80

DRAWING NO.
SN-14

PS&E DESIGN
MARCH 2022
Not for Construction

3/22/2022 R:\2019\08_0001\010_Traffic_Eng_Des_JMT\Task_17 - Park_Place_PBL\Draw_Signing\PSN-014_Park_PI_NW.dgn

DESCRIPTION	REVISION						
	DATE	COR.	CHK.	APP.	APP.	APP.	APP.

REG	STATE	PROJECT	SHEET NO.	TOTAL SHEETS
3	D.C.		62	80

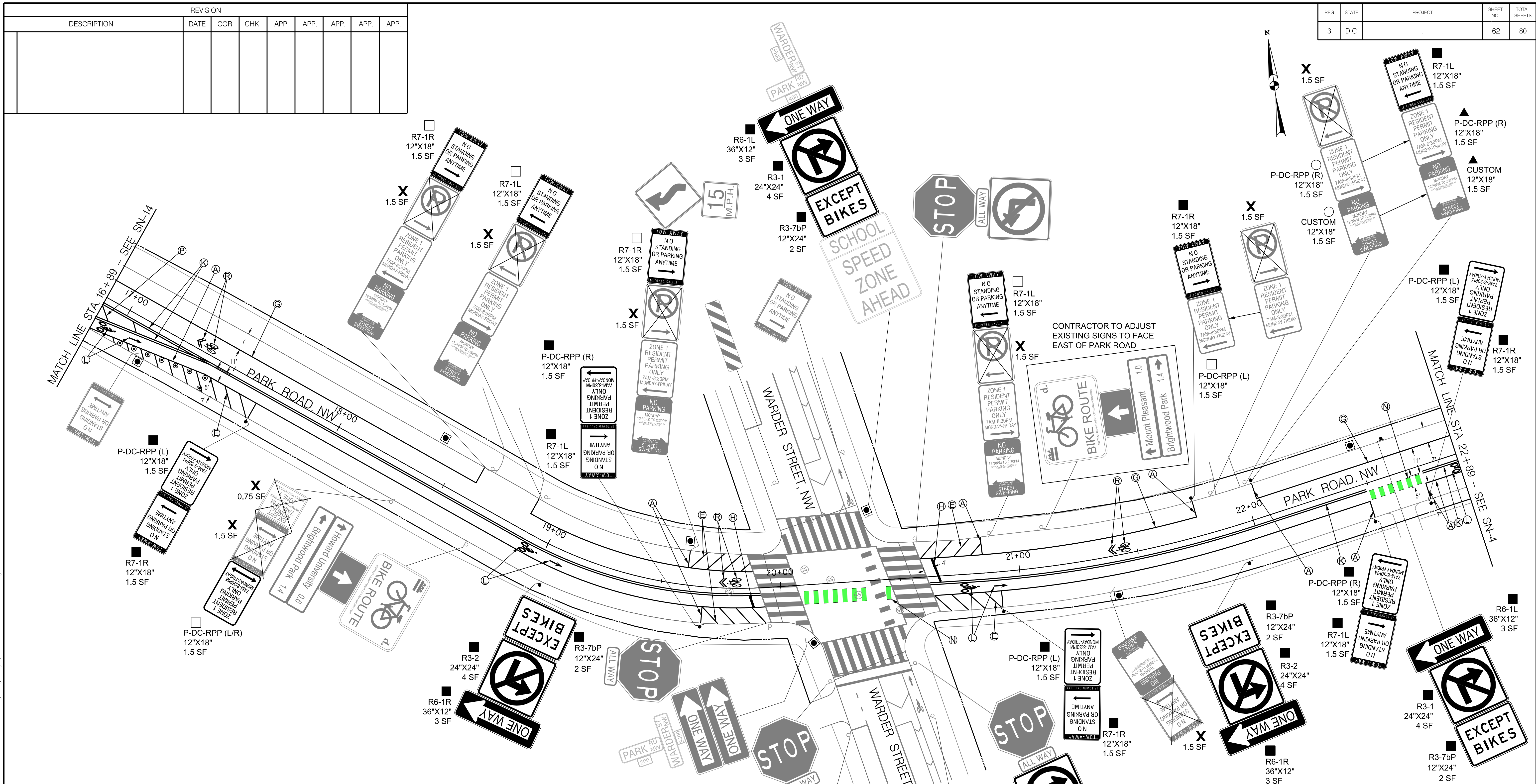

SIGNING LEGEND

- ALL EXISTING SIGNS SHALL REMAIN IN PLACE UNLESS OTHERWISE NOTED.
- X EXISTING SIGN TO BE REMOVED
 - EXISTING SIGN TO BE RELOCATED
 - △ EXISTING SIGN RELOCATED TO EXISTING POST OR EXISTING SIGNAL POLE / LIGHT POLE
 - ▲ EXISTING SIGN RELOCATED TO NEW POST
 - NEW SIGN TO BE INSTALLED ON EXISTING POST OR EXISTING SIGNAL POLE / LIGHT POLE
 - NEW SIGN TO BE INSTALLED ON NEW POST

PAVEMENT MARKING LEGEND

- Ⓐ 4 INCH SOLID WHITE LANE LINE
- Ⓑ 4 INCH DOTTED WHITE LANE LINE (2' STRIPE, 4' SKIP)
- Ⓒ 4 INCH DASHED WHITE LANE LINE (10' STRIPE, 30' SKIP)
- Ⓓ GORE MARKINGS WITH 4 INCH SOLID WHITE LINES (15' O.C. AT 45 DEGREES)
- Ⓔ DIAGONAL MARKINGS 4 INCH SOLID WHITE LINES (5' O.C. AT 45 DEGREES)
- Ⓕ DIAGONAL MARKINGS 4 INCH SOLID WHITE LINES (7.5' O.C. AT 45 DEGREES)
- Ⓖ 6 INCH SOLID WHITE LANE LINE
- Ⓗ 12 INCH WHITE STOP BAR
- Ⓙ 24 INCH WHITE CROSSWALK STRIPE
- Ⓚ 4 INCH DOUBLE SOLID YELLOW LANE LINE
- Ⓛ WHITE BICYCLE LANE SYMBOL OR ARROW
- Ⓜ GREEN COLORED PAVEMENT WITH 4 INCH LANE LINE BORDER
- Ⓝ 24" GREEN BICYCLE CROSSING FOR ONE WAY BIKE LANE (SEE DETAIL ON SHEET SN-DE2)
- Ⓟ DIAGONAL MARKINGS 4 INCH SOLID YELLOW LINES(15' O.C. AT 45 DEGREES)
- Ⓠ YIELD LINE SYMBOL
- Ⓡ WHITE SHARROWS
- Ⓢ DIAGONAL MARKINGS 12 INCH SOLID WHITE LINES (15' O.C. AT 45 DEGREES)
- Ⓣ GORE MARKINGS WITH 12 INCH SOLID WHITE LINES (10' O.C. AT 45 DEGREES)

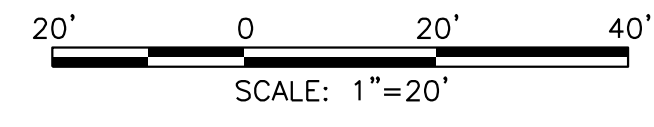

Mead & Hunt
 100 M STREET SE SUITE 550
 WASHINGTON, DC 20003
 (202) 570-7080
 WWW.MEADHUNT.COM

S.I.F. NO. _____
 APPROVED BY _____ DATE _____

PS&E DESIGN
 MARCH 2022
 Not for Construction

DISTRICT OF COLUMBIA DEPARTMENT OF TRANSPORTATION TRAFFIC ENGINEERING AND SAFETY DIVISION		FINAL
PARK PLACE /5TH STREET – PROTECTED BIKE LANE FROM HOBART PLACE NW TO GRANT CIRCLE NW, PARK ROAD WESTBOUND ONE-WAYING FROM PARK PLACE NW TO GEORGIA AVENUE NW SIGNING AND PAVEMENT MARKING		FIELD CHECKED BY MP/TK
DESIGNED BY MP	DRAWN BY MP	REVIEWED BY RF
DATE 03 / 2022	SCALE 1" = 20'	SHEET 62 OF 80
APPROVED:	DATE:	DRAWING NO. SN-15

3/22/2022 RA:2019.08 DD01 ID:0 Traffic Eng_Designer:JMT:Task 17 - Park Place_PBL\Draw\Signing\PSN-015_Park PI NW.dgn